

[Start](#)

Burrs

The origin of the word 'burr' is a little hard to trace, but it is likely it comes from the English word 'burr', a carpenter's tool to make holes or notches. Whether the word applies to the tools that may be used to manufacture the wooden pieces, or to the fact that the pieces 'burr' each other, is left for you to decide. In the context of puzzles, however, it is used for a puzzle consisting of notched 3-dimensional puzzle pieces. The pieces lock together and form a geometric attractive shape.

The Chinese cross burr puzzle is one of the best known burr puzzles. Here you can see a picture of the puzzle when it is put together.

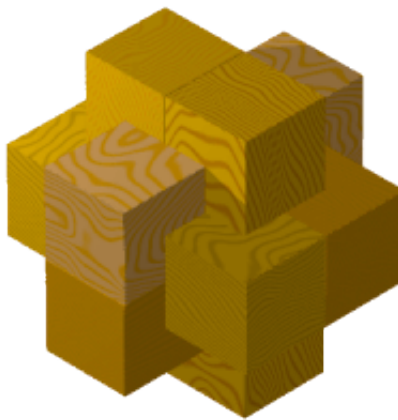

The puzzle consists of 6 right angled pieces that two by two intersect perpendicularly. In this case the measurements are $2 \times 2 \times 6$ units, but the length can also be 8, 10 or 12 units. It turns out that the four mentioned lengths each allow for their own corresponding burrs, but that lengths larger than 12 do not introduce new burrs.

For years I have spent time designing puzzles of this type, because I have been charmed by the simple elegance of the shape of the puzzle and the limited number of pieces the puzzle consists of. On top of this, the difficulty is surprising! I will elaborate on this furtheron.

There are two kinds of Chinese cross puzzles:

1. The inside is massive. (massive burrs)

If the inside is massive and the puzzle can be taken apart, then the pieces can only move in a certain direction when in doing so, the pieces 'follow themselves'. This means that if you find any piece (or group of pieces) that moves, you just have to continue to move this piece in the found direction to free it. After that the two remaining parts of the puzzle readily fall apart.

Pieces without internal corners are called notchable and can be most easily made. When trying to construct a massive burr with notchable pieces, it turns out that there are 25 different pieces you will ever have to use. Bill Cutler's analysis shows that with these pieces you can construct exactly 314

solutions, comprised in 221 burrs. You will need some pieces twice or thrice. You will find a complete list of all notchable pieces [here](#); with them you can make all 221 massive burrs, which will be given furtheron. See also under 2.

Massive burrs come in various types, depending on the way they disassemble. Roughly, there are 5 types:

- the first move frees one piece (this then must be the massive piece A),
- the first move frees 2 pieces,
- the first move frees 3 pieces,
- the first move can be one out of two, the first freeing 2 pieces, the second freeing 3 pieces,
- the first move can be one out of two, the first freeing 3 pieces, the second freeing also 3 -different-pieces.

2. The inside contains holes. (holey burrs)

If the inside contains holes, then a moving piece may be blocked by another piece after being moved. Pieces may become stuck in a certain direction. In this way one can have a burr where first a number of pieces have to be moved in various directions, before the first piece is freed. Two consecutive moves are counted as only one if both moves, possibly concerning different pieces, are in the same direction. The number of moves you need to free the first piece is called the **level** of the burr.

Remark. With the notchable set of length 8 many holey burrs are possible with levels varying from 2 to 7. See below for a selection of burrs of length 8 ordered by difficulty.

Using the notchable set, the highest possible level for a burr with a unique solution is 4. With the set, no burrs are possible with level higher than 7 for lengths 8 and 6.

The set at length 10 allows for exactly one burr with a level 8 solution. The solution is not unique, though. It is the burr **FLOYYY**. With the notchable set no burrs at any length are possible with a higher level than 8.

1. Massive Burrs with the notchable set

One may be lead to believe that the first kind of burr, a massive bur, is simple. But looks deceive. Taking the puzzle apart may be easy, putting it together is a whole different story. Trying to put together the pieces, one may find configurations of the pieces that look perfect **on paper**, in that all pieces according to position and shape fill the entire burr without overlapping, but **in reality** the configuration can not be taken apart, and therefore neither be put together! This is called a false solution (and therefore is nota solution). This is caused by the fact that in a false solution, all pieces obstruct eachother, leaving no room for movement. A (*real*) solution is a configuration that can be put together *and* (*or*) can be taken apart. The false and real solutions together are called *possible* solutions or *assemblies*.

From this point of view **BLPXXY** with 4 assemblies and 1 solution is most difficult.

Also **CDPQRY** with 8 assemblies and 6 solutions is remarkable.

The problem is to find a real solution. If one tries to go through all configurations, trying each piece at each position, there are **3840** possible configurations when using six *normal* (see explanation below) pieces are used.

One counts the number of configurations as follows. A piece may be placed in one of six positions in a burr. These positions are filled consecutively. Choose a starting piece among the six and put it at the first position. This accounts for a factor 1 (instead of 12), because however you would put all the pieces in the burr, it may be rotated such that the starting piece is at this chosen position. So, rotation of a burr counts as an identical configuration. For the second position, one has a choice of 5 remaining pieces and each may be placed in two ways (end for end flip), giving a factor 10. For the third position, one has a choice of 4 remaining pieces and each may be placed in two ways (end for end flip), giving a factor 8, etc. This gives a total of $10 \times 8 \times 6 \times 4 \times 2 = \mathbf{3840}$ possible configurations of the six pieces.

The **index** of six given pieces is the number of configurations one has to consider to find all possible solutions, taking into account the form of the pieces and the number of copies of each piece used. Computation of the index is a first step in computing an objective measure for the difficulty of the burr. The higher the index, the longer our search takes before we will find a solution, at least in principle. It would be handy to be able to compare all burrs on the basis of an objective measure for the difficulty.

Intermezzo.

One would like to be able to compare all burrs with each other by associating a number to each burr indicating its difficulty in an objective way. Although the index is a first step in this direction, it is not 100% satisfying.

Firstly, it does not take into account the number of real solutions. The more real solutions there are, the easier it becomes to find one. The difficulty of a burr is measured by the effort necessary to find the first solution. Burrs with equal index do not necessarily have the same number of solutions and therefore do not have to be equally difficult. One can easily fix this problem by dividing the index by the number of real solutions. The result will be the average number of configurations for each solution.

Secondly, the index does not take into account the number of false solutions. If a burr allows for many false solutions, then this means that it does not give up the solution that easily. After all you will be able to find configurations that would be a possible solution. How does one determine if a possible solution is a real one or a false one? Indeed, by puzzling. Since at first you have not put the pieces together yet, this means you have to determine by using logic why a solution would be real or false. Only after you have determined that the solution is indeed real, you may hope to find a way to put the pieces together.

Can we express these experiences into one number? I will give it a try.

The difficulty of a burr reasonably is measured by the number of configurations you have to search through (tries) before you find the first solution. If we assume that the configurations are searched in a random order and that the solutions are distributed at random amongst these, implying that every solution has the same chance to be found first, then we can compute the expected number of configurations you have to search through before you find the first solution. Let us call this number $N(S,C)$, where S is the number of real solutions and C is the total number of configurations containing these solutions. If we know the index, then C will be taken equal to the index. We will now determine a formula for $N(S,C)$.

To start with, one has that

$$N(S,C) = S/C + (C - S)/C \times (1 + N(S, C - 1)).$$

Because with probability S/C we find the first solution already at our first considered configuration; at that time there are still S solutions to be found and the contribution to the expectation is S/C tries to find a solution.

If we fail at our first try, then with probability $1 - S/C = (C - S)/C$ we have to search through the $C - 1$ configurations that are left. We then want to know the average number of tries to find a real solution out of S possible solutions within $C - 1$ configurations. But that is precisely $N(S, C - 1)$. Since we had already used a trie we have to add 1 to this number. Therefore the contribution to the expected number of tries is in this case equal to $(C - S)/C \times (1 + N(S, C - 1))$.

From this (a so called 'recursive') relation we may deduce that $N(S,C) = (C + 1)/(S + 1)$. It is easily checked that this does satisfy our relation for $N(S,C)$. Do we take C to be equal to the index (I) then $N(S,I)$ must be a better measure for the difficulty of a burr. Note that $N(S,C)$ resembles the expression C/S , that intuitively equals the average number of configurations for each solution. The difference is that $N(S,I)$ is the expected number of tries you have to undertake before you arrive at a solution. $N(S,I)$ does not yet take into account the number of false solutions. See below for more information.

We will now indicate how you compute the index. Then we will elaborate on the difficulty of burrs some more.

The standard index is 3840 like we have seen earlier. This index holds when a burr consists of 6 'normal' pieces.

A normal piece is one that is different from A, E, F, G, K, S, T and X; everyone of the mentioned pieces has the property that its usage will either increase or decrease the number of configurations. The corresponding factors will be considered next.

Multiply the index by a factor **2** or **4** for each **ambiguous** piece involved.

An ambiguous piece is one that may be rotated along its long axis by multiples of 90 degrees and still not cause external holes at the outside of the burr. Some may also be flipped end by end, so they can be used in even more ways.

These pieces are S, T (factor 2) and E, F, G (factor 4).

From this point of view the puzzles **FNOPRT** and **FLPRTY** are most difficult (and their mirror images of course). Their index is $2 \times 4 \times 3840 = \mathbf{30,720}$, also the highest possible number of configurations you have to search through for 6 pieces of a massive burr.

NOTE. The burrs **GNOPQT** (the mirror image of FNOPRT) and **DGNOPQ** are known as burr #306 and #305 according to an earlier analysis by Bill Cutler, for their high index and because these two burrs can be made using only 7 pieces. These burrs have a lock of 3 pieces and that makes them very satisfying!

Their 'little brothers' are **FLPRTY** and **CFLPRY**, which have the same index, but have a lock of 2 pieces and therefore are a little less admirable. Note that these can also be made using only 7 pieces, or if you have the previous by adding 2 pieces (pieces L and Y).

Now, do we take into account the difficulty that is defined below, all these burr share their **first place** with **LNOPST** (first mention!) which has 3 possible solutions of which 1 real one.

Divide the index by a factor **2** for **unimodal** pieces.

A unimodal piece is one which has the same form, when it is flipped end-for-end and which is not ambiguous. Such a piece can be used only 'in a single way'.
These pieces are A, K, X.

We shall now see that when a burr uses some equal pieces, the number of configurations decreases.

Divide the index by a factor **2**, when **two equal** pieces are used; divide the index by a factor **6** when **three equal** pieces are used. (For massive burrs, no more than three equal pieces are ever used.)

Equal pieces may switch position, without having an effect, therefore counting as the same configuration.

From this point of view the puzzle **ALLXXX** is easiest with only $3840 / 2 / 2 / 2 / 2 / 2 / 6 = 20$ configurations, since 2 normal pieces and 4 unimodal pieces are used ($/ 2 / 2 / 2 / 2$), one piece (L) occurs twice ($/ 2$) and one piece (X) occurs thrice ($/ 6$).

Divide the index by the **number** of solutions possible with the current selection of pieces.

When searching through all possible configurations, it is clear that one will find the easier a solution with te pieces, the more solutions there are to be found. The index is thus defined as the number of possible configurations per solution. Requiring all solutions to be found, increases the difficulty again with the same factor...

A list of all possible massive burrs with the notchable pieces can be found [here](#). The list is sorted in the order of difficulty.

Note. For burrs without *false* solutions, the difficulty simple equals $N(S,I)$, where I is the index and S is the number of solutions. See below for a further explanation of the used measure for difficulty, which also takes the number of false solutions into account.

One had better use **logic** to eliminate most of the configurations as possible solutions, rather than using brute force, trying them all one by one. But that is not always easy either ... If eventually you have found a configuration that seems a possible solution, you still have to find a way to assemble the pieces! And *that* may very well be impossible! It could be a false solution! Then you are back to square one and the search goes on.

Summary. There is a wide variety of massive burrs that may be constructed with the notchable set, because the number of configurations to search through varies from **20** to **30,720**. A massive burr has between 1 and 8 possible solutions of which there are between 1 and 6 real solutions.

2. Holey Burrs with the notchable set

The notchable set is suitable for constructing a wide range interesting holey burrs with higher level

solutions. One could make the set of length 6, 8, 10, 12 or longer. Using a length longer than 10 will not introduce any more burrs: all burrs with a length longer than 10 behave the same as the length 10 burr. So it does not seem advisable to use such long lengths, unless you appreciate the visual aspect.

For the interested readers among you, I have got the complete analysis of the holey burrs (burrs with at least 1 hole).

[Length 6 \(335 KB\)](#)

[Length 8 \(332 KB\)](#)

[Length 10 \(332 KB\)](#)

Length 12 (equal to Length 10)

With thanks to Keiichiro Ishino, who computed these results. A link to his page can be found below.

Be aware of the following, regarding these analysis:

- The decimal codes are 1 lower as defined on the IBM BurrPuzzle page.
- Every piece may occur as much as 6 times, so the analysis does contain burrs which are not possible with the notchable set, like YYYYYY. The analysis is broader than strictly necessary for the notchable set, but that is O.K. for completeness sake. After all, the notchable set was conceived with its basis in the massive burrs.

Regardless, the analysis has its own value. Besides, among the burrs possible with the notchable set you will find some very interesting ones!

I prefer the set at length 8. According to me this length allows for the most interesting burrs, but that is a personal taste. There are two tendencies for the set at length 8. Firstly, the burrs at length 8 possess less real solutions than at length 6, although the number of possible solutions is equal. Secondly, the burrs at length 8 in general have a lower level, but the number of holes may be larger. Both tendencies contribute to the difficulty of the resulting burrs.

From the analysis it turns out that there are exactly 5 burrs (and their mirror images) with a unique level 4 solution. Here they are in decreasing difficulty.

CINTVY : (1/8) 4

CINRXY : (1/4) 4

CDINXY : (1/4) 4

CILRXY : (1/3) 4

CINNOX : (1/3) 4 (Recommended! This burr wins my beauty prize)

7 burrs (and their mirror images) have exactly 2 solutions, one of level 2 and the other of level 5. These burrs are especially recommendable, because they allow for a gradual satisfaction. First you can take your time to find the solution with level 2 (considered easier) and then go on and try to find the level 5 solution. Here they are in decreasing difficulty.

FLMQXY : (2/17) 2 5

FLMOVX : (2/14) 2 5

LMNTWX : (2/14) 2 5

FLOVXX : (2/18) 2 5

FLOQXX : (2/16) 2 5

FILOXX : (2/14) 2 5
CFLOXX : (2/13) 2 5

The following links are to textfiles. The layout may not be perfect, but the contents are complete for the set of 42 pieces of the notchable set at length 8. (Treasure these!)

- [Unique solutions with minimal level > 1](#) ordered by difficulty (**1169 burrs**)
- [Non unique solutions with minimal level > 1](#) ordered by difficulty (**3527 burrs**)
- [Non unique solutions with maximale level > 3](#) ordered by maximal level (subset of previous)
- [Statistics unique length 6](#)
- [Statistics unique length 8](#)
- **Statistics unique length 10** (Equal to length 8!)
- [Statistics non-unique length 6](#)
- [Statistics non-unique length 8](#)
- [Statistics non-unique length 10](#)

Remarkable: the only differences between the non-unique length 10 and 8 are

- the burrs with minimal level 1. At length 10 the numbers are slightly shifted in favor of higher maximal level.
- the burrs with minimal level > 1. At length 10 **identical** to length 8, **except** for the following 4 burrs.
- the burrs **VWXXXY** (10 holes), **NVWXXX** (9 holes), **LVWXXX** en **MVWXXY** (both 8 holes), which all have only level 3 solutions and are not possible at length 10.

You will not ever regret having the notchable set at length 8, because all mentioned holey burrs are possible. Have you mastered the 221 massive burrs then you still have these 4696 interesting holey burrs to solve.

You will notice that the holey burrs are much more difficult than the massive burrs, because of their many false solutions. They are real mind benders. Even the level 2 burrs are much more difficult than you would expect. You may assume that the mentioned difficulty is proportional to the time you need to find a solution. See below for an explanation.

I would like to mention here some very special burrs, surfacing from the analysis. The following burrs have a record number of solutions, or possible solutions or false solutions. Most solutions are level 1, however.

FLNOYY : (666/712)
FGNOYY : (662/764)
FGNOWY : (183/389) 206 false solutions

Comparing lengths 6 and 8, it turns out there are slightly less unique burrs for length 6, namely 5 less. On the other hand there are slightly more unique burrs for length 6 with level > 2 is slightly larger, namely 21 more. However, at length 6 you do NOT have the 1-hole burr **CDMQUY** with 2 solutions, both level 2.

At length **6** there are only **three** unique level 5 burrs. Compare this to the nice set of burrs at length 8 with 2 solutions, mentioned above. Here they are.

LMQSXY : (1/7) 5.2

LNRSXX : (1/6) 5

LLNSXX : (1/4) 5

Moreover, at length six, there are 7 burrs (and their mirror images) with a unique level 4 solution.

We proceed again with length 8. The following burr has several solutions, most with a high level (7) for length 8 and all their solutions are at least level 2. The first is really an exceptional burr, since the number of solutions is so limited.

LLUMTY : (6/7) 7 6(2) 4 3 2

OUTYLC : (17/22) 7 6(2) 4.2 4 3.2 3(3) 2.2 2(7)

The first burr has 7 possible solutions of which 6 are real. Of these, 1 is level 7, 2 are of level 6 and there are 3 more solutions of level 4, 3 and 2 respectively. This burr equals its mirror image.

The second burr has 17 solutions, of which 8 of level 2 and 9 of level at least 3.

There are some more higher level burrs possible with the notchable set. If the highest level is as high as 7, then normally there are many low-level solutions too. This makes them not that interesting, because finding the higher level solution is like looking for a needle in a haystack and no fun. For completeness sake, I mention them here.

OLUMTY (22/34), **OUTYLC (17/22)**, QLUOTY (30/34), ILUOTY (49/59), LNJMTY (15/36), LLWMTY (7/11), WLUOTN (76/82), **LLUMTY (6/7)**, CNOTUY (48/53), INOTUY (70/79), LNOTUV (23/36), LMOTVY (64/86), LMNTVY (40/56).

The first 8 of these, I had found on Bill Cutler's pages, but there they were hidden completely under a haystack of LL-codes... The other 5 I found from the analysis of Keiichiro Ishino. Most of them have many level 1 solutions and it is very (too) difficult to find the level 7 solution. Maybe you can make them more interesting? For instance, if you would be able to find an adequate marking of the pieces, much like the markings for Love's Dozen, you could make the solution unique.

We have seen a lot of burrs, each of which is most difficult from a certain point of view. Can we objectively assert the difficulty of a burr?

Intermezzo. (continued)

Like mentioned before when addressing the massive burrs, we will now go deeper into the difficulty of the holey burrs. If I (the index) is the number of possible configurations, S the number of solutions, and P the number of possible solutions (= real + false solutions), the difficulty $D(S,P,I)$ would then intuitively satisfy the following relation:

$$D(S,P,I) = N(P,I) \times S/P + (P - S)/P \times (N(P,I) + D(S, P - 1, I - N(P, I))).$$

The formula for $D(S,P,I)$ means that you count all configurations you go through before you find a solution: first you go through $N(P,I)$ configurations before you arrive at a the first possible solution, which is a real solution with possibility S/P and a false solution with possibility $1 - S/P = (P - S)/P$. If it is a false solution, then you have already tried

$N(P,I)$ configurations and so you will need to go through the remaining $I - N(P,I)$ configurations, only now you have only $M - 1$ possible solutions you may find. This recursive formula has the following surprising solution:

$$D(S,P,I) = N(S,I).$$

Indeed, the solution equals the earlier defined $N(S,I)$. Apparently $D(S,P,I)$ does NOT depend on the number of possible solutions, hence not on the false solutions. That is not entirely according to experience, but theoreticly this is to be expected. Because, in our search we are really looking only for solutions, and whatever intermediate configurations we come along, be it a possible solution, real or false, or just any other configuration, we do not care. In the end, the formula should just be telling us the number of configurations we have tried, and that equals $N(S,I)$. In a way this is a relief, because it shows that the formula for $N(S,I)$ is correct.

We now have to correct the problem, because in our experience any false solution encountered adds to the difficulty of the burr. I propose the following correction as a measure for the difficulty:

$$D(S,I) = N(S,I) \times N(S,P)$$

This means that burrs with equal $N(S,I)$ are being distinguished by the added factor $N(S,P)$ which gives a larger number for cases where $P > S$. My assumption is, that for two burrs with equal $N(S,I)$ the elimination of impossible configurations is 'equally difficult'. You can interpret the factor $N(S,I)$ as the expected time before you find a possible solution, thought of as independent of the number of possible solutions, and the factor $N(S,P)$ as the expected number of possible solutions you will find before you find a real solution. Note that when you find a false solution, you practically have to start all over.

If two burrs have the same index and number of solutions, then the one with the more possible solutions is more difficult, because you are bound to go through some of these false solutions first, namely $N(S,P)$.

An intuitive interpretation of the formula is that the difficulty of the burr, expressed by $D(S,I)$, is proportional to the expected number of trials before you find a real solution *and* proportional to the expected number of possible solutions you will find during this search, of which all but the last are false. Although the theoretical basis is not complete, an example may clarify that it is reasonable.

Example. Look at the burrs **ENNRYY** and **CMORUW**, both of which have a unique solution. Both have an index of 3840, but the first has 26 possible solutions (how do you place the piece E?), while the second has no false solutions. You would expect the first to be much more difficult, precisely by a factor $N(1,26) = 13.5$. The difficulty of the first becomes $N(1,3840) \times N(1,26) = \mathbf{25,927}$, while the second has difficulty $N(1,3840) \times N(1,1) = \mathbf{1921}$. Does it really matter that CMORUW's solution is level 4, while ENNRYY's solution is 'only' level 3? I leave it up to you to experiment with this.

Is the difficulty of a burr really defined proportional to the time somebody would need to

solve it? If somebody would need 1 minute to solve a burr with difficulty 50, than one would expect the same person to need 50 minutes for a burr of difficulty 2500. Somebody else may use different times but in the same proportions, for instance 5 minutes to solve a difficulty 50, hence 4 hours and 10 minutes to solve a difficulty 2500.

By actually logging the times you need to solve a certain burr, especially in connection to the difficulty, you could help test the hypothesis. I am really curious about your findings; does it work according to you? I would love to hear it from you. You are then contributing to a possible correction to the proposed formula.

You will not regret having a notchable set. You are able to make a wide range of burrs. I have collected several higher level burrs [here](#), ordered according to difficulty index. The list is not complete by far, but remarkable. The burrs mentioned above are already left out, because of their unfeasability. However, these higher level burrs are much more difficult than you would expect, because they often have a lot of false solutions (sometimes more than 50). They are really tough and astounding in difficulty, even most level 2 burrs will keep you busy for hours. The list also shows the mass of the burr. (32 minus the mass is the number of holes in the burr.) The list is remarkable because it contains 'maximal' burrs, that is, you can not add a unit to the burr without dropping the number of solutions to zero (or obtaining unnotchable pieces). In other words, the burrs have as little holes as possible with the notchable set.

Summary. ***

Holey burrs with the notchable set are even more numerous. Their index varies from 20 (**MMXXXY**) to 61,440 (**EFNOQY**). However, this classical index is not an accurate measure for the difficulty for this kind of burrs, it is merely a lower bound. Namely, the difficulty increases with the number of false solutions. For example, since **EFNOQY** has 12 false solutions, its corrected index is $(12 + 1)/1 \times 61,440 = \mathbf{798,720}$. The number of false solutions may be very high. The burr **FGINOY** has as much as **151** false solutions and only 4 similar level 2.2 solutions; its corrected index is $(151 + 4)/4 \times 15,360 = \mathbf{599,040}$. This means that this burr has difficulty only 75% of the difficulty of **EFNOQY**, despite its large number of false solutions. From this point of view, the most difficult burr I found possible with the notchable set is **FILTVY**. This 'monster' has 36 false solutions and a unique solution (level 3); its corrected index is **1,136,640**. Try this one, if you dare...

Open question. Using the notchable set at length 8, is there a unique level 4 burr? At least no unique level 5 burr exists, since these all require length 6. Please, let me know when you have the answer (affirmative or not).

3. Holey Burrs, the story

In 1991 I got inspired by some burrs of the hand of Bill Cutler and others, put together in the dutch book 'Puzzels, zelf maken en oplossen' (Puzzles, how to make and solve them) written by Jack Botermans and Jerry Slocum (ISBN 90 697 6026 6, Trendboek BV and ADM International BV). I found the book then, although it was written in 1986. In the book, 4 higher level burrs are mentioned (these are called 'The Fearsome Four') and the suggestion was raised if there might be even more complicated burrs of this type with higher levels than already discovered. Bill had received designs with higher and higher levels in the course of writing the book.

The open question triggered my curiosity and I started designing my own burrs. First I made Lego models (Lego is a well known construction toy) and admired these curious puzzles. They really baffled me, after having known only the massive burrs of the past.

In 1993, the last year of my study, I designed many higher level burrs. My method was to choose a sequence of moves beforehand and from there I deduced the consequences for the shape of the individual pieces of the puzzle. This was done 'by hand'. No computer aid here. The method had a 'flaw' in that it did not guarantee that the pieces had a unique solution and wrote to Bill to analyse my designs with his program.

Eventually I designed a high **level 12** burr, of which even the second piece could be freed only after **another** 3 more moves! On top of that, I had put in two different kind of traps. The first trap would be to move the wrong piece first, then one gets stuck after 2 moves. The second trap is more subtle. One gets stuck again when a certain piece is moved too far. It is harder to solve, because it is easily overlooked that the piece should be **exactly** in the right place to allow for yet another piece to move. Not only is it difficult to find the way to put the pieces together, it was now also hard to take the pieces apart! The solution of the puzzle is not unique, but the pieces can be marked at the ends easily to make it unique after all. Thanks to Bill Cutler for pointing this out, later. (See the pieces of this puzzle [here](#).)

I talked to Bill Cutler at a dutch 'puzzle party' in the same year, and showed him my self made burr of this design. He looked at the design. He said that he had just done a complete analysis by computer of all Chinese burrs and that **this** design came up as the record with the highest possible level. My disappointment was somewhat tempered by his adding that this puzzle had been designed already in 1987 by Bruce Love, living in New Zealand, and this puzzle is called Love's Dozen after him. Of course I was stunned, but there's no way I could ever have designed the puzzle as early as 1987, just starting my study. But there was some comfort in the thought that occurred to me, that I could **level** with the world's best puzzlers. Not bad at all!

If you want to know even more about burrs, look at the following links, where a treasure of information can be found.

- [Bill Cutler](#)
- [IBM's Burr Puzzle Site](#) (here you can find and compute solutions to **all** Chinese burrs)
- [IP \(Interlocking Puzzles\)](#)
- [Keiichiro Ishino](#) (burr catalogue. Recommended!)

4. Some of my designs

An **extended level** of a burr is a sequence of numbers separated by a dot (.). The first number indicates the number of moves necessary to free the first piece, the second number the number of moves needed **extra** to free the seconde piece, etc.

- [Unique level 7.1.2](#)
- [Unique level 6.4](#)
- [Unique level 5.6](#) (Note: $6 > 5$, so the second piece is freed 'more difficult' than the first!)
- [Only 2 solutions: level 5 and level 6](#)

5. Bonus for Love's Dozen

Love's Dozen has 89 solutions, of which 6 have a level higher than 3 (one of which is the level 12). Everyone can find at least one solution for himself. As a bonus I give a hint to find the other five higher level solutions. Look closely to the drawing and next read on.

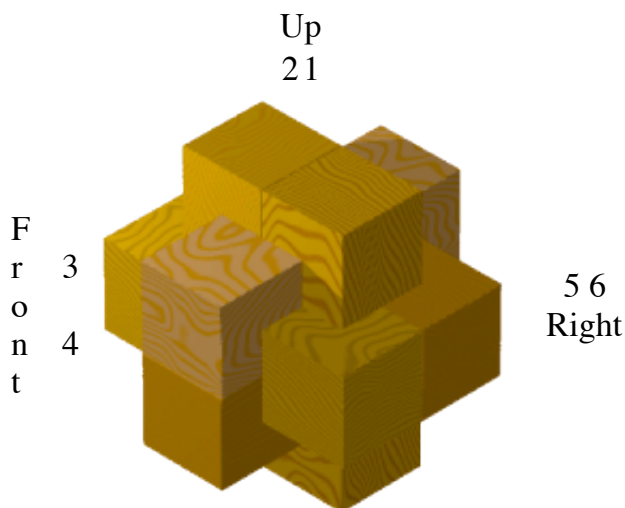

In the drawing, each **position** of a piece gets a number. Position 1 and 2 are vertical, the others horizontal, position 3 and 4 go from front to back, positions 5 and 6 go from right to left.

Next, if one uses the coding of the pieces according to a description, it is possible to indicate with a sequence of six letters (for massive burrs) or numbers (for holey burrs) which piece goes to which position.

Example. The sequence 563142 means that piece 5 of the description goes to position 1 in the drawing, piece 6 to position 2, etc.

In the table below, the pieces are code as indicated in the description of [Love's Dozen](#).

The sequences give a hint to the solution, but give nothing away about the moves involved. In any case, it saves you to go through all 89 solutions!

Love's Dozen		
Coding Position/Piece		Extended Level
123456		
??????		12.3
643521		6.3
213564		4.4
243561		4.4
563142		4.2 (2x)

Use this table as an exercise before you try the level 12 solution (for which you have the markings as a hint)

or as an extension to this **lovely** burr.

Have fun!

Page-log

Date Remark

- 19-4-
2002 Piece 5 of my non-unique 6-5 design corrected.
- 30-4-
2002 Some textual corrections and adding of holey burrs possible with notchable set. Have fun!
- 11-5-
2002 Added a link to the startpage and some remarks about the difficulty index for holey burrs.
- 4-7-
2002 Completed the list of higher level burrs with a corrected index, taking number of assemblies into account.
- 6-7-
2002 Corrected the corrected index and the explanation for it, as well as the table with holey burrs.
- 7-7-
2002 The previous 'correction' was undone. The explanation has been adjusted again to take away any doubts, and the correct table is put back.
- 16-9-
2004 The page has been updated to match the Dutch pages. The reason this has not been done before is that there is still an issue regarding the correct determination of the difficulty index. I will try to address this topic in a future update. I thought that the data on this page has its own worth, even if it is not 100% correct.



(last update 16-09-2004)

Complete notchable set.

The set consists of 25 different pieces, 42 together with some double ones. Behind every piece there is the number of pieces needed to be able to make all massive burrs. Recommendation: take length 8 instead of 6. See Comment on previous page.

The binary code indicates of 12 units if they are present (1) or not (0). Read more about it at the burr-puzzle page.

Binary code 111111111111 A, 1x

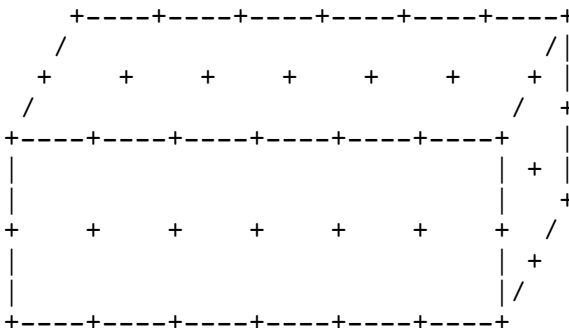
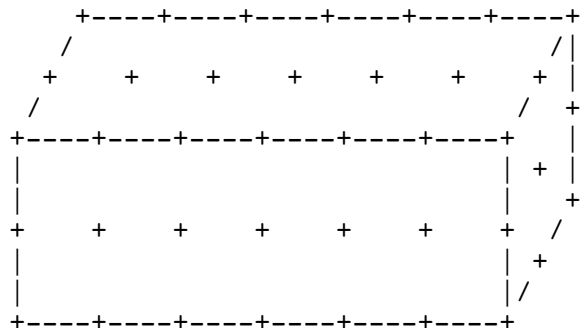

Binary code 111011101111 B, 2x

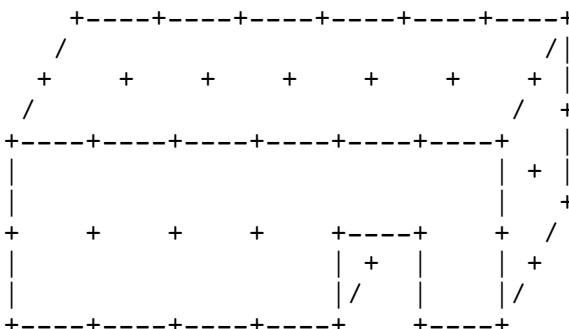
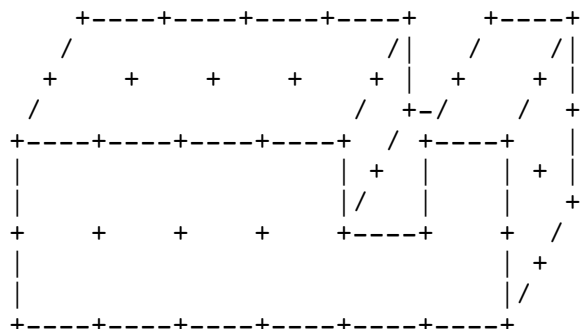

Binary code 100011100011 C, 2x

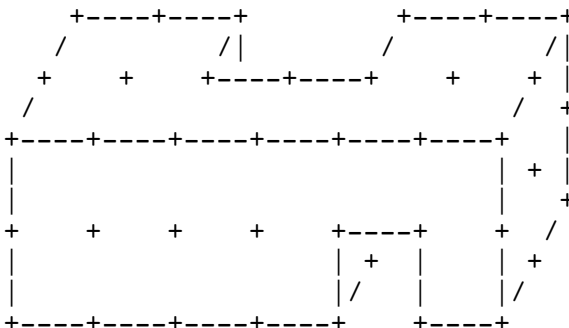
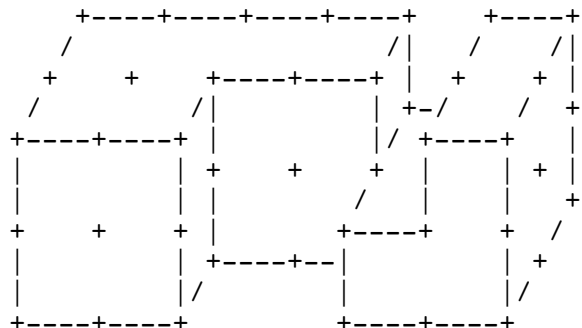

Binary code 000101110011 D, 2x

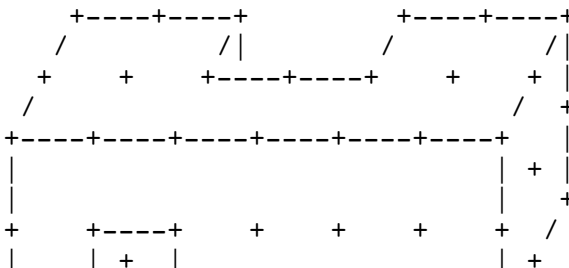
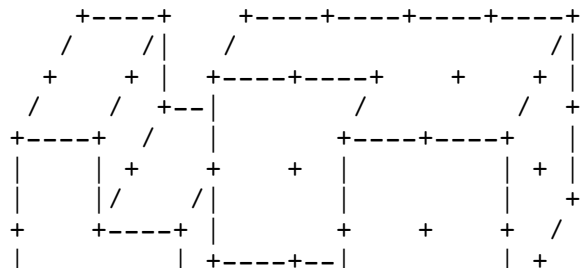

| / | /
+---+---+ +---+---+ | /

| / | / | / | /
+---+ +---+ +---+ +---+ | /

Binary code 101110111111 E, 1x

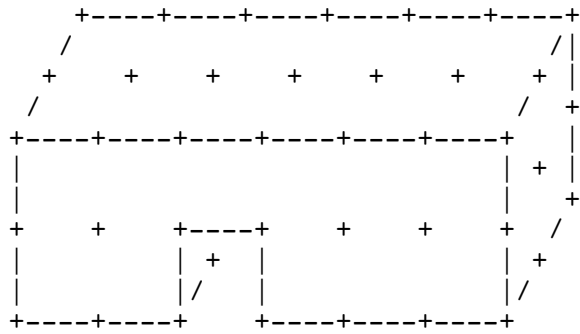
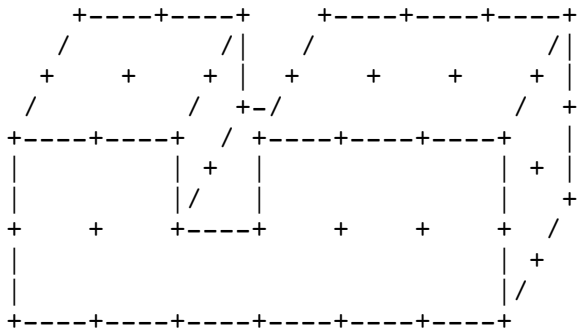

Binary code 100111010011 F, 1x

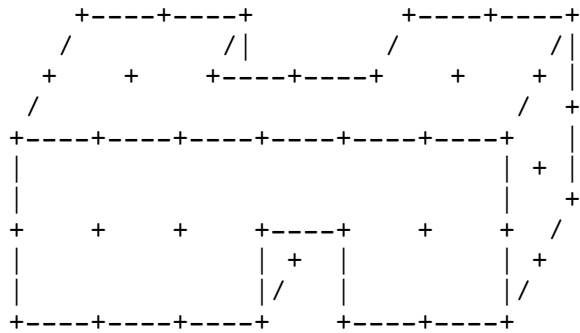
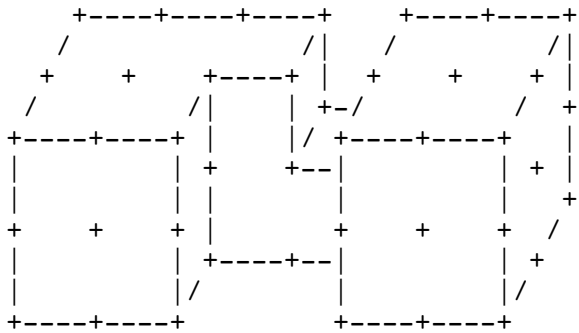

Binary code 100110110011 G, 1x

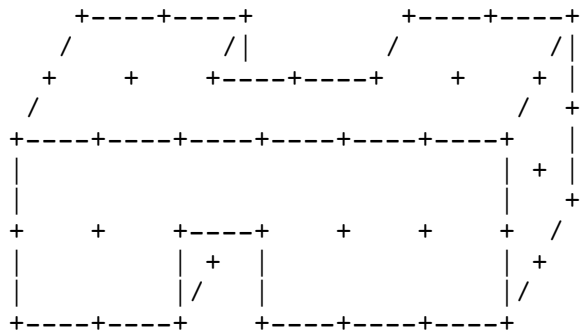
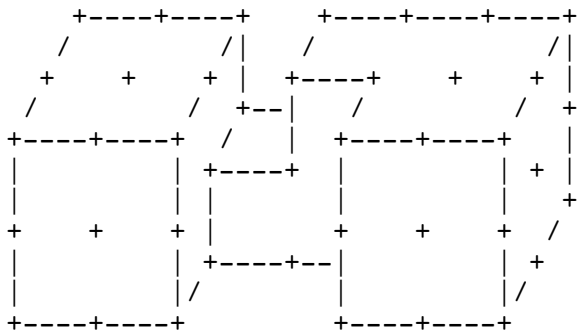

Binary code 101010101111 H, 1x

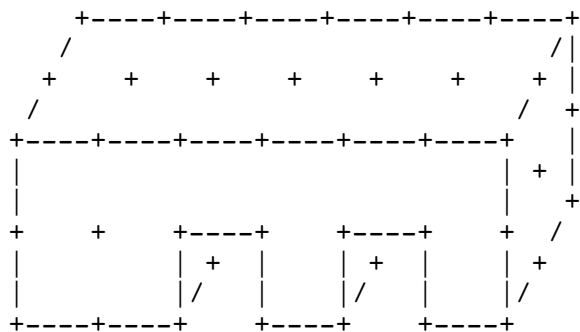
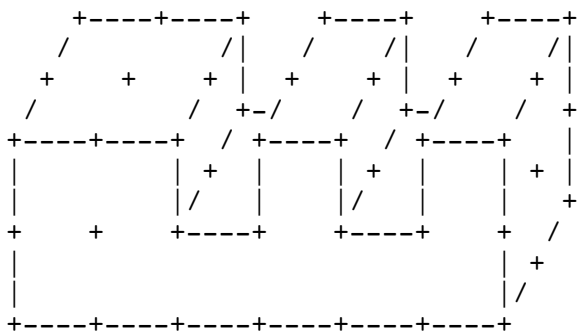

Binary code 100010100011 I, 1x

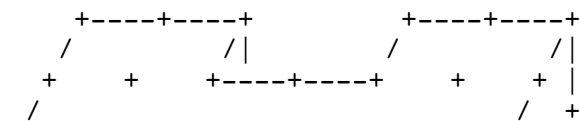
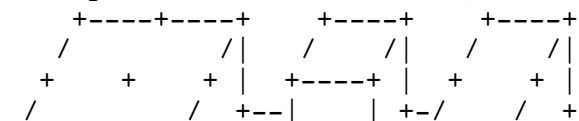

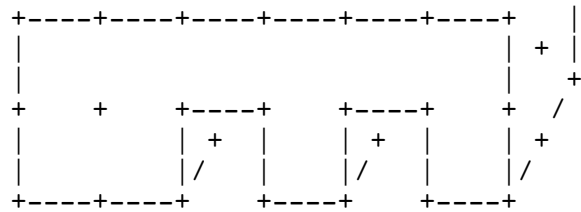
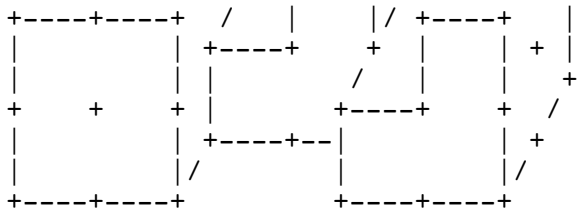

Binary code 000101010011 J, 1x

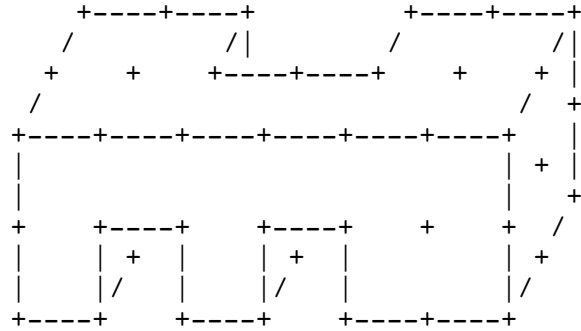
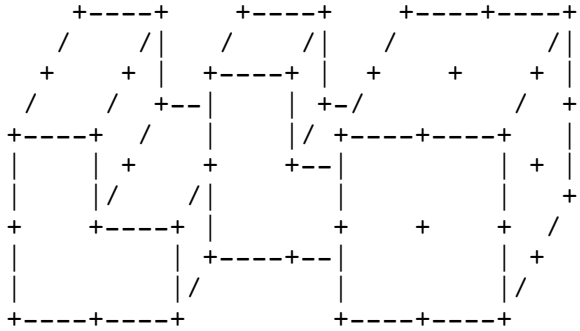

Binary code 011001101111 K, 1x

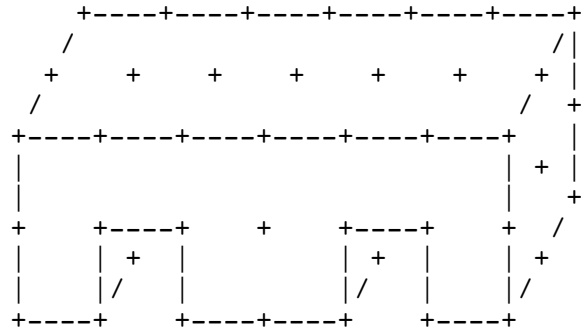
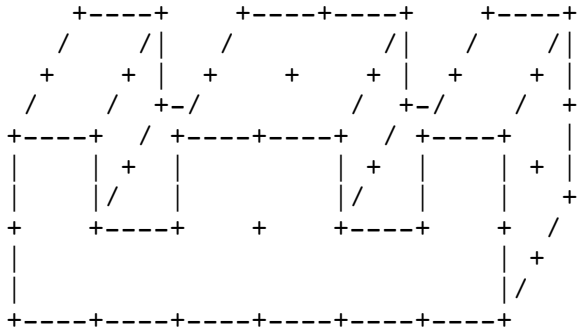

Binary code 000001100011 L, 2x

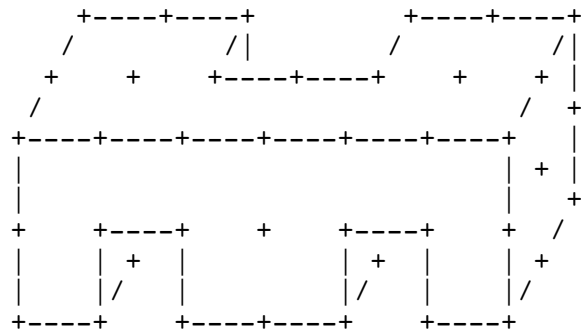
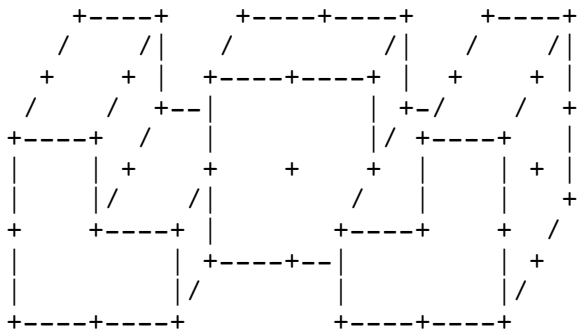

Binary code 010001001111 M, 2x

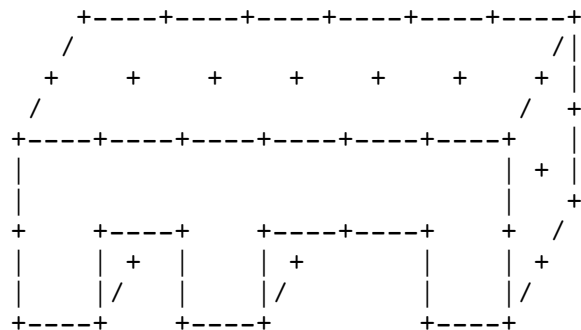
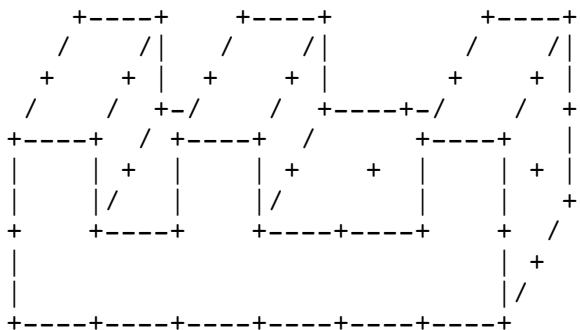

Binary code 000000100011 N, 2x

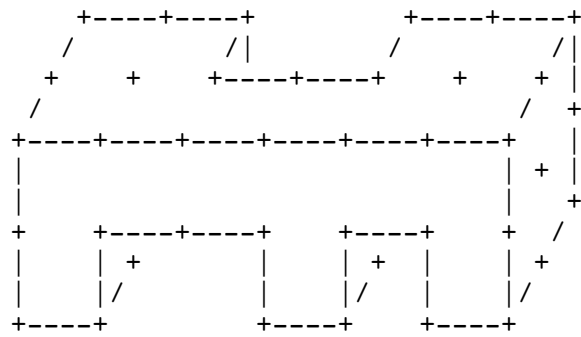
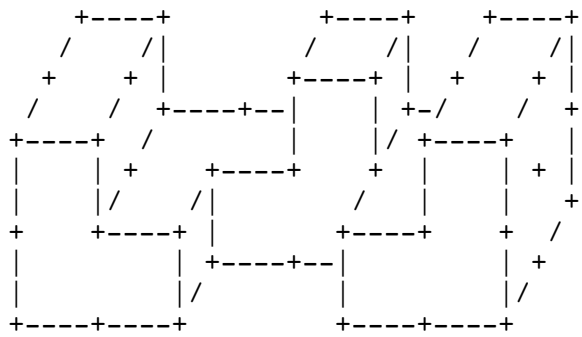

Binary code 000001000011 O, 2x

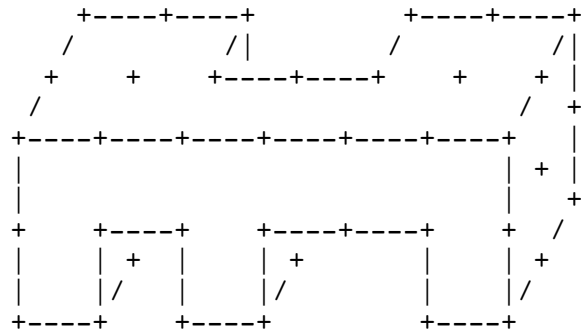
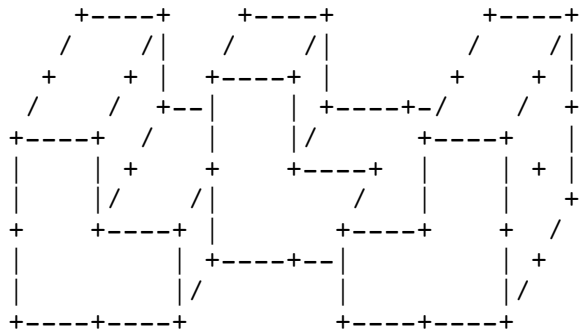

Binary code 110011001111 P, 2x

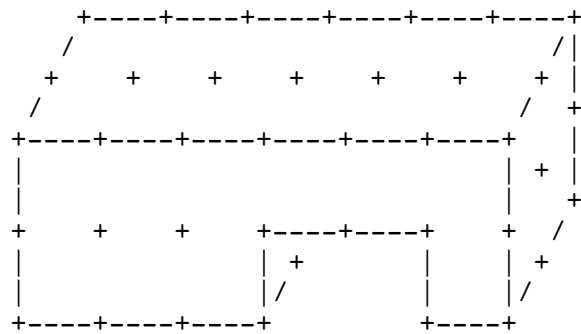
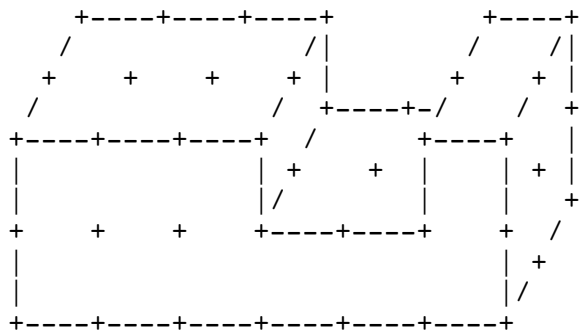

Binary code 100011000011 Q, 2x

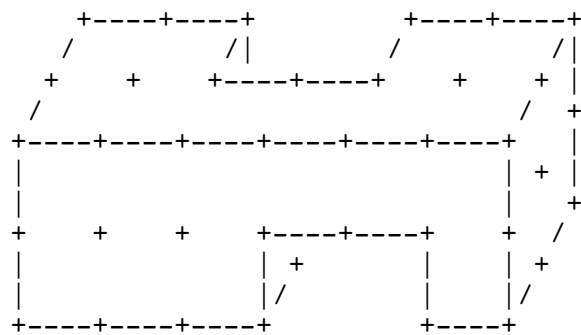
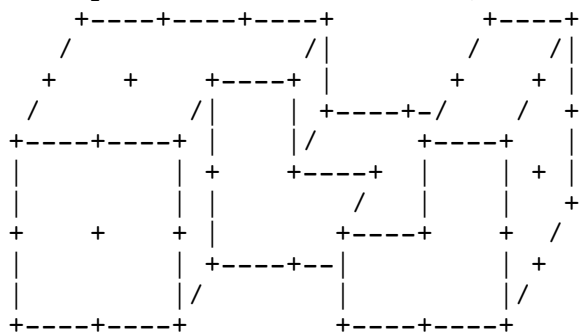

Binary code 000100110011 R, 2x

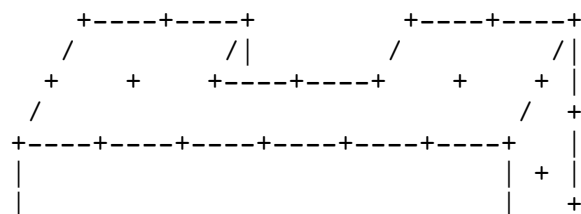
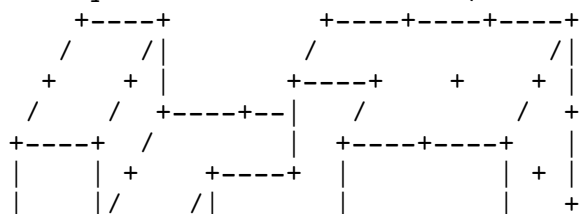

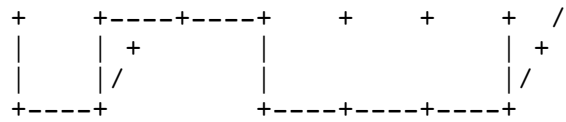
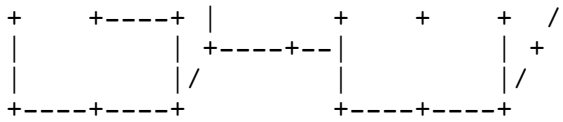

Binary code 100110011111 S, 1x

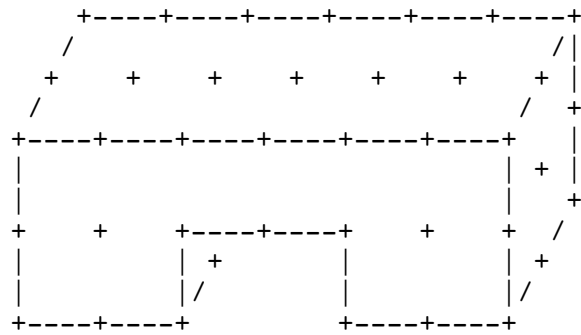
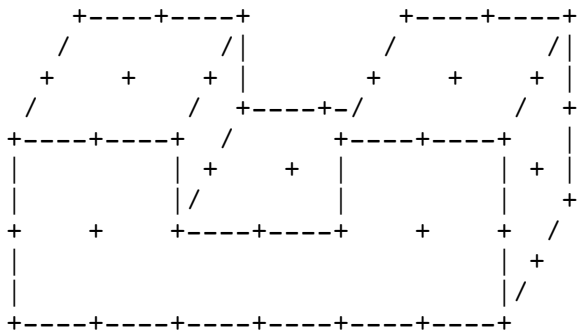

Binary code 100110010011 T, 2x

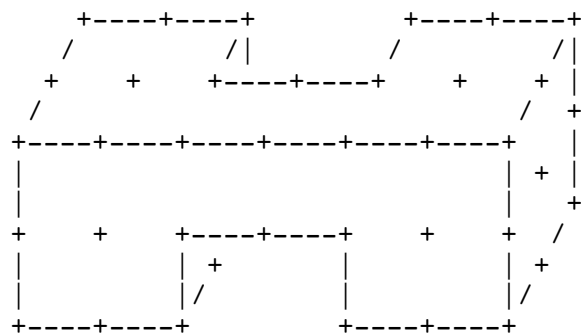
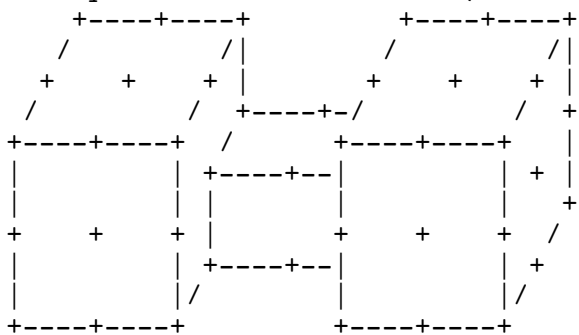

Binary code 000100011111 U, 1x

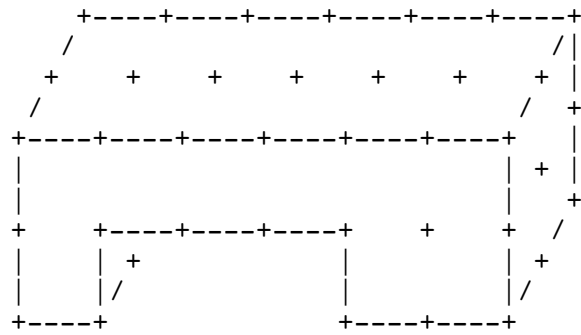
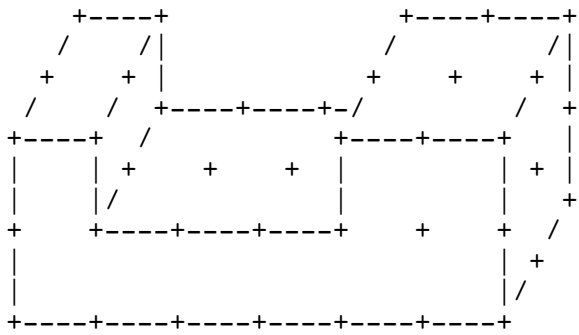

Binary code 100010000011 V, 2x

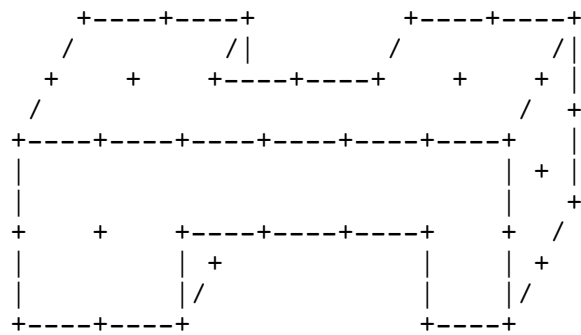
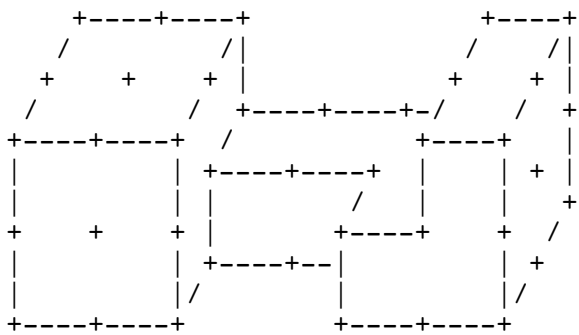

Binary code 000100010011 W, 2x



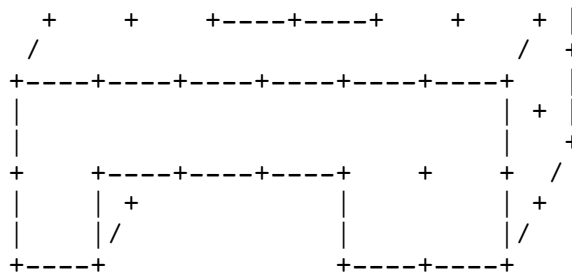
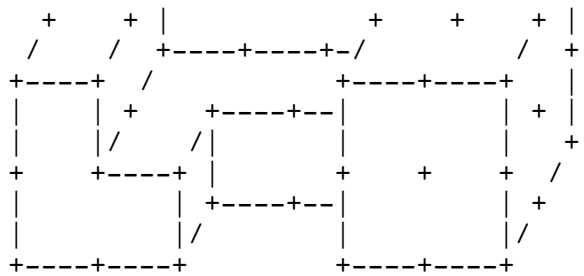

Binary code 000000001111 X, 3x

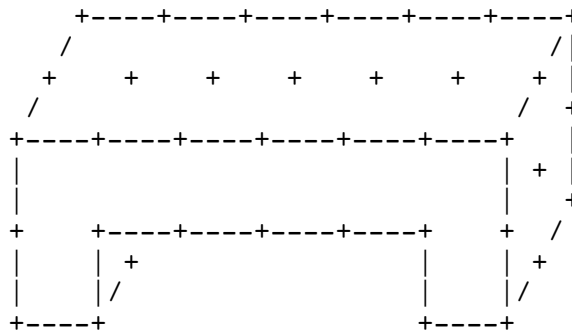
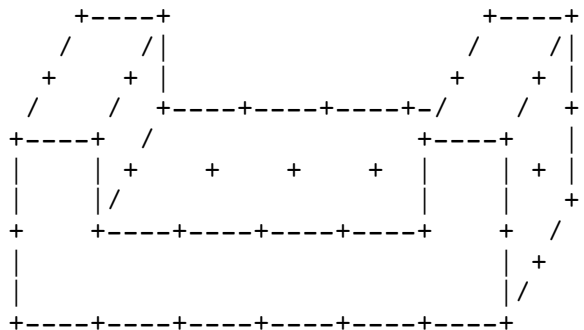

Binary code 000000000011 Y, 3x

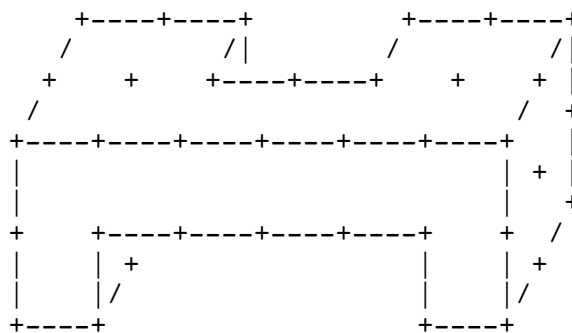
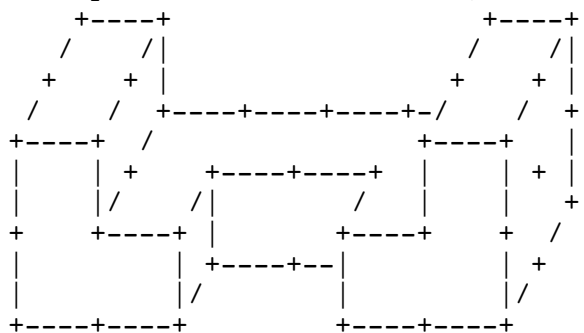

(last update 15-09-2004)

Massive burrs with the notchable set / Massieve burrs met de freesbare set

Legenda

(English)

BurrCode = Used pieces according, coded as mentioned elsewhere

Index = The classical index, not using the number of solutions and/or assemblies

Diff. = Difficulty according to proposed formula. This should be proportional to the time you need to solve the burr.

Sol. = Number of real solutions for the mentioned burr.

Asm. = Number of assemblies = number of false plus number of real solutions.

(Dutch)

BurrCode = Gebruikte stukken, volgens eerder genoemde codering.

Moeil. = Moeilijkheid volgens voorgestelde formule. Deze zou evenredig moeten zijn met de tijd die je nodig hebt om de burr op te lossen.

Opl. = Aantal echte oplossingen

Mog. = Aantal mogelijke oplossingen = aantal valse oplossingen plus aantal echte oplossingen.

Burr Code	Index	Diff. Moeil.	Sol. Opl.	Asm. Mog.
ALLXXX	20	11	1	1
AKXXYY	60	31	1	1
BBXXYY	120	61	1	1
LLPPXX	120	61	1	1
ACCXY	240	121	1	1
ACLXY	240	121	1	1
ACNOXX	240	121	1	1
ADDXY	240	121	1	1
ADLXY	240	121	1	1
ADNOXX	240	121	1	1
AKVXY	240	121	1	1
AKWXY	240	121	1	1
ALMXY	240	121	1	1
AMMXY	240	121	1	1
AMNOXX	240	121	1	1
ANNQXX	240	121	1	1
AOORRX	240	121	1	1
AKTYYY	320	161	1	1
AMPYYY	320	161	1	1
ALNOUX	960	240	3	3

ANOPXY	960	240	3	3
ANPQYY	960	240	3	3
AOPRYY	960	240	3	3
CDPPYY	960	240	3	3
CDQQR	960	240	3	3
ACCWYY	480	241	1	1
ACMXYY	480	241	1	1
ADDVYY	480	241	1	1
ADMXYY	480	241	1	1
ALLUXY	480	241	1	1
ALPXYY	480	241	1	1
BBVXYY	480	241	1	1
BBWXYY	480	241	1	1
ACORXY	960	320	2	2
ADNQXY	960	320	2	2
ALNQWX	960	320	2	2
ALORVX	960	320	2	2
ALQRXY	960	320	2	2
AMNQXY	960	320	2	2
AMORXY	960	320	2	2
AMQRYY	960	320	2	2
ANOQRX	960	320	2	2
ANQQR	960	320	2	2
AOQRRY	960	320	2	2
BCPXYY	960	320	2	2
BDPXYY	960	320	2	2
CLPPXY	960	320	2	2
DLPPXY	960	320	2	2
AHTYYY	640	321	1	1
AMSYYY	640	321	1	1
BBTYYY	640	321	1	1
ANOSXY	1920	480	3	3
ANQSY	1920	480	3	3
AORSYY	1920	480	3	3
BCPWYY	1920	480	3	3
BDPVYY	1920	480	3	3
COPPRY	1920	480	3	3
DNPPQY	1920	480	3	3
NOPPQR	1920	480	3	3
ACLQYY	960	481	1	1
ACLUYY	960	481	1	1

ACLWXY	960	481	1	1
ACMVYY	960	481	1	1
ACNOWX	960	481	1	1
ACNQXY	960	481	1	1
ACQRYY	960	481	1	1
ADLUYY	960	481	1	1
ADLVXY	960	481	1	1
ADMWYY	960	481	1	1
ADNOVX	960	481	1	1
ADORXY	960	481	1	1
ADQRYY	960	481	1	1
AINOOU	960	481	1	1
AJNNOU	960	481	1	1
ALMVXY	960	481	1	1
ALMWXY	960	481	1	1
ALPVYY	960	481	1	1
ALPWYY	960	481	1	1
ALSXYX	960	481	1	1
AMNOVX	960	481	1	1
AMNOWX	960	481	1	1
BBVWYY	960	481	1	1
BMMUYY	960	481	1	1
CNOPPX	960	481	1	1
DNOPPX	960	481	1	1
LNPPQX	960	481	1	1
LOPPRX	960	481	1	1
BLPXXY	480	601	1	4
ACNOUY	1920	640	2	2
ACNQWY	1920	640	2	2
ADNOUY	1920	640	2	2
ADORVY	1920	640	2	2
AILOUY	1920	640	2	2
AJLNUY	1920	640	2	2
ANOPVY	1920	640	2	2
ANOPWY	1920	640	2	2
BCQRXY	1920	640	2	2
BDQRXY	1920	640	2	2
BPQRYX	1920	640	2	2
CLPQRX	1920	640	2	2
COPQRR	1920	640	2	2

DLPQRX	1920	640	2	2
DNPQQR	1920	640	2	2
LPPQRY	1920	640	2	2
BPSYYY	1280	641	1	1
CDPQRY	3840	705	6	8
BNPQWY	3840	768	4	4
BOPRVY	3840	768	4	4
AMNOTY	3840	960	3	3
ANOTUY	3840	960	3	3
NOPPSY	3840	960	3	3
ACIOWY	1920	961	1	1
ACORVY	1920	961	1	1
ADJNVY	1920	961	1	1
ADNQWY	1920	961	1	1
AINOQW	1920	961	1	1
AIQTYY	1920	961	1	1
AJNORV	1920	961	1	1
AJRTTY	1920	961	1	1
ALMTYY	1920	961	1	1
ALQRVY	1920	961	1	1
ALQRWY	1920	961	1	1
ALSVYY	1920	961	1	1
ALSWYY	1920	961	1	1
ALTUYY	1920	961	1	1
ALTVVY	1920	961	1	1
ALTWWY	1920	961	1	1
AMNOUY	1920	961	1	1
AMNQVY	1920	961	1	1
AMNQWY	1920	961	1	1
AMORVY	1920	961	1	1
AMORWY	1920	961	1	1
ANOQRV	1920	961	1	1
ANOQRW	1920	961	1	1
ANOTVV	1920	961	1	1
ANOTWW	1920	961	1	1
BMPVYY	1920	961	1	1
BMPWYY	1920	961	1	1
BNQQRW	1920	961	1	1
BOQRRV	1920	961	1	1
CLPPWY	1920	961	1	1
CNOPPW	1920	961	1	1

DLPPVY	1920	961	1	1
DNOPPV	1920	961	1	1
LMMPUY	1920	961	1	1
LMPPVY	1920	961	1	1
LMPPWY	1920	961	1	1
LPPSY	1920	961	1	1
ANOSVY	3840	1280	2	2
ANOSWY	3840	1280	2	2
ANQTVY	3840	1280	2	2
AORTWY	3840	1280	2	2
BCQRWY	3840	1280	2	2
BDQRVY	3840	1280	2	2
BQRSY	3840	1280	2	2
BLPVXY	1920	1441	1	2
BLPWXY	1920	1441	1	2
BNOPVX	1920	1441	1	2
BNOPWX	1920	1441	1	2
ILOPPW	1920	1441	1	2
JLNPPV	1920	1441	1	2
LNPPQW	1920	1441	1	2
LOPPRV	1920	1441	1	2
BNOPTY	7680	1920	3	3
BNPQXY	1920	1921	1	3
BOPRXY	1920	1921	1	3
AFLRY	3840	1921	1	1
AFNNOW	3840	1921	1	1
AGNOOV	3840	1921	1	1
AIOTVY	3840	1921	1	1
AJNTWY	3840	1921	1	1
BIOPWY	3840	1921	1	1
BJNPVY	3840	1921	1	1
BLPTY	3840	1921	1	1
BMQRVY	3840	1921	1	1
BMQRWY	3840	1921	1	1
LMPQRV	3840	1921	1	1
LMPQRW	3840	1921	1	1
AFLNWY	7680	2560	2	2
AFNORY	7680	2560	2	2
AGLOVY	7680	2560	2	2
AGNOQY	7680	2560	2	2

LPQRSY	7680	2560	2	2
NOPQRS	7680	2560	2	2
BETYYY	5120	2561	1	1
BMNQUY	3840	2881	1	2
BMORUY	3840	2881	1	2
LMNPQU	3840	2881	1	2
LMOPRU	3840	2881	1	2
BCFRYY	7680	3841	1	1
BDGQYY	7680	3841	1	1
BHNOTY	7680	3841	1	1
BNOSUY	7680	3841	1	1
BNQSWY	7680	3841	1	1
BNQTTY	7680	3841	1	1
BORSVY	7680	3841	1	1
BORTTY	7680	3841	1	1
LNPQSW	7680	5761	1	2
LNPQTT	7680	5761	1	2
LOPRSV	7680	5761	1	2
LOPRTT	7680	5761	1	2
ENOPTY	30720	7680	3	3
HLNOPT	7680	7681	1	3
LNOPSU	7680	7681	1	3
BFIORY	15360	7681	1	1
BFRTYY	15360	7681	1	1
BGJNQY	15360	7681	1	1
BGQTTY	15360	7681	1	1
BNOSTY	15360	7681	1	1
CFLPRY	15360	7681	1	1
CFNOPR	15360	7681	1	1
DGLPQY	15360	7681	1	1
DGNOPQ	15360	7681	1	1 #305
ELPTY Y	15360	7681	1	1
FILOPR	15360	11521	1	2
GJLNPQ	15360	11521	1	2
LNOPST	15360	15361	1	3
FLPRTY	30720	15361	1	1
FNOPRT	30720	15361	1	1
GLPQTY	30720	15361	1	1
GNOPQT	30720	15361	1	1 #306

Holey burrs with the notchable set (length 8) / Holte burrs met de freesbare set (lengte 8)

Legenda:

English

Index Corr. Correct difficulty index \sim Index * #asm / #sol
 Index Difficulty index on the basis of the pieces
 alone.
 Code Code of the burr (necessary notchable pieces)
 Level Between brackets the number of solutions with
 the indicated level. Different levels are
 separated by a hyphen.
 #Sol Number of solutions
 #Asm Number of assemblies: all true and false
 solutions.
 Weight Number of unit cubes occupied inside the burr
 (max. 32 for massive)

Nederlands

Index corr. Correcte moeilijkheidsindex \sim Index * (#VO +
 #O)/#O
 Index Moeilijkheidsindex op basis van de stukken
 alleen
 Code Code van de burr (benodigde freesbare stukken)
 Niveau Tussen haakjes staat het aantal oplossingen met
 het betreffende niveau; verschillende niveaus
 zijn gescheiden door een streepje
 #Opl Aantal oplossingen
 #VO+#O Aantal valse oplossingen + aantal echte
 oplossingen
 Gewicht Aantal gevulde eenheidskubusjes in de burr (max.
 32 voor massieve burr)

Index Corr.	Index	Code	Level Niveau	#Sol. #Opl.	#Asm #VO+#O	Weight Gewicht
960	240	CCIOXX	3	1	4	28
960	960	CCDJYY	2	1	1	27

960	960	CCDOVY	3-2	2	2	27
960	960	CCLNWX	4-2	2	2	25
1280	640	CCIOUY	3-2 (2)	3	6	28
1707	1280	CLTUVY	4-3 (2) -2 (3)	6	8	28
1920	1920	CCNORW	2	1	1	27
2400	960	CCQSYX	3-2	2	5	29
2560	1280	CCFLYX	3-2 (2)	3	6	27
2821	1097	FILOOU	5-3 (2) -2 (4)	7	18	28
3840	1920	LLSSXY	2	1	2	30
3840	3840	CDIJNY	2	1	1	27
4800	960	KUTXYX	2	1	5	28
5547	1280	CLNSXY	4 (2) -2	3	13	27
5760	1920	KNSWXY	3	1	3	29
5760	1920	KPTVYX	2	1	3	30
6240	960	CFLOXX	5-2	2	13	28
6827	2560	CDLFYX	3-2 (2)	3	8	27
6827	2560	ISTTYX	4-2 (2)	3	8	29
6827	2560	NSTTVY	4 (2) -2 (4)	6	16	29
7680	960	KOPUYX	3	1	8	29
7680	3840	HLLTUY	2	1	2	30
7680	7680	CDFNUY	2 (2)	2	2	30
9387	2560	CFLOUY	5-3-2 (4)	6	22	28
9600	1920	KUTVYX	2	1	5	28
9600	1920	MOQSXY	3 (2)	2	10	28
10240	5120	ELNOTX	2 (3)	3	6	30
11520	1920	KNRUWY	2	1	6	28
15360	7680	ELLTXY	2	1	2	30
17203	6144	FNQTTY	4 (2) -2 (3)	5	14	29
17280	3840	FHLQYX	3-2	2	9	28
18773	5120	LMOSTY	4.3 (2) -1	3	11	29
23040	3840	ILOOSU	3	1	6	29
23040	7680	LLSTUY	2	1	3	30
23040	7680	FLNSWX	4.3-3	2	6	29

26880	1920	CHLOXY	3	1	14	27
26880	7680	CFTTY	4-2	2	7	29
26880	7680	FNQTTY	4 (2) -2 (2)	4	14	29
30720	7680	LSTVWX	2	1	4	30
32640	3840	FLMQXY	5-2	2	17	28
34560	3840	FJLNNU	3 (2)	2	18	28
38400	7680	CLOSUY	2	1	5	29
38400	7680	COGSXY	2 (2)	2	10	30
46080	15360	MNQSTY	2	1	3	30
46080	7680	CFOSXY	2 (2)	2	12	30
53760	15360	FLNRSY	4.3-3	2	7	29
69120	7680	LMTUVY	2	1	9	28
69120	7680	FHLOVY	2 (2)	2	18	28
76800	15360	CLOSTY	2	1	5	29
76800	15360	FGIJXY	2 (2)	2	10	30
76800	15360	FGLVWX	2 (2)	2	10	30
84480	7680	CCFTYY	2	1	11	29
92160	15360	FMQSY	2	1	6	30
92160	15360	CFOTUY	2 (2)	2	12	30
99840	3840	EOOQYY	3	1	26	25
107520	15360	CFOTVV	2	1	7	30
122880	15360	FIQQTY	2	1	8	30
130560	15360	FGNOVW	2 (4)	4	34	28
133120	10240	FGNOUY	2 (6)	6	78	28
153600	30720	FGMVWY	2 (2)	2	10	30
161280	15360	FJNTTY	2 (2)	2	21	29
168960	15360	FNOOTT	3	1	11	28
184320	15360	FNNOTT	2	1	12	28
184320	30720	EFLYYQ	2	1	6	30
184320	15360	FLNTTY	2 (2)	2	24	28
192000	15360	FNOSTY	2.2 (2) -2 (2)	4	50	29
245760	30720	FGLQQY	2	1	8	30
245760	30720	FGLRRY	2	1	8	30

245760	30720	FGNOQQ	2	1	8	30
245760	30720	FGNORR	2	1	8	30
291840	15360	FGLUYY	2 (2)	2	38	28
307200	30720	FLTUVY	2	1	10	29
337920	30720	FIOQTV	2	1	11	30
368640	30720	CGOSVY	2	1	12	30
368640	30720	CGOSVY	2	1	12	30
399360	30720	CFQTVY	2	1	13	30
399360	30720	FJSTYY	2	1	13	30
399360	30720	FOSTWY	2 (2)	2	26	30
430080	30720	CFOSVY	2	1	14	30
430080	30720	FLQSVY	2	1	14	30
430080	30720	FNOQSV	2	1	14	30
476160	15360	FJNOSY	2.2 (2)	2	62	28
537600	30720	FGTVYY	2 (2)	2	35	28
537600	30720	FGNTVY	2 (4)	4	70	29
599040	15360	FGINOY	2.2 (4)	4	156	27
645120	30720	FJNTTY	2	1	21	29
645120	30720	FLTTWY	2	1	21	29
645120	30720	FNOTTW	2	1	21	29
675840	30720	FLOTTY	3	1	22	28
798720	61440	EFNOQY	2	1	13	30
1136640	30720	FILTVY	3	1	37	28

With gratitude towards Keiichiro Ishino for computing the total number of solutions.
 Met dank aan Keiichiro Ishino voor het berekenen van het totaal aantal oplossingen.

(last update / laatste aanpassing 07-07-2002)

Burr BC UL7000 7-1-2

LL-format 55351100113054221110043624620606

Length 6

Piece 1

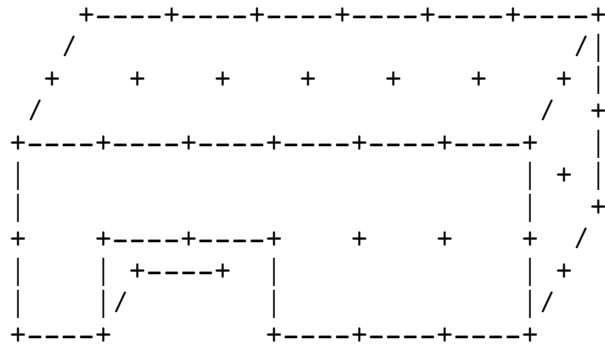
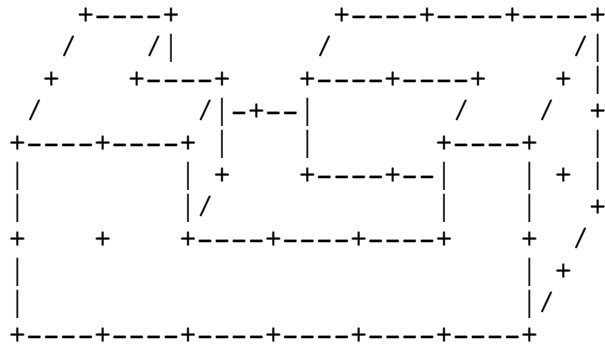

Piece 2

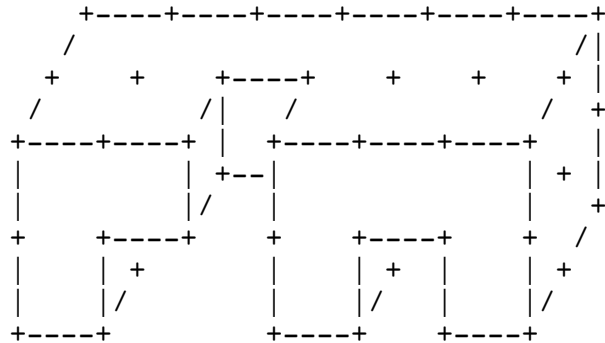
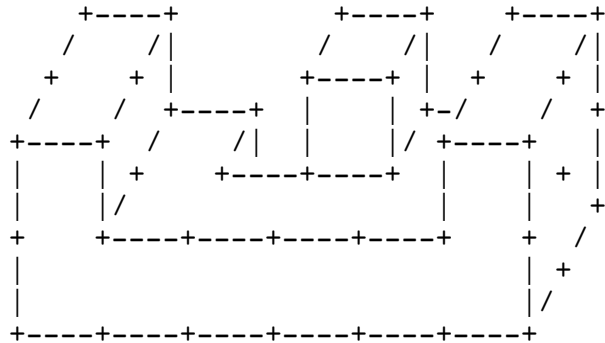

Piece 3

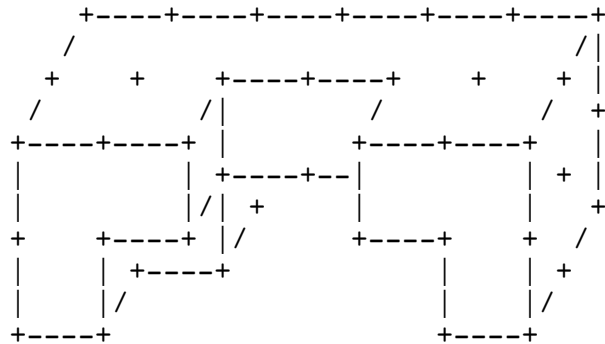
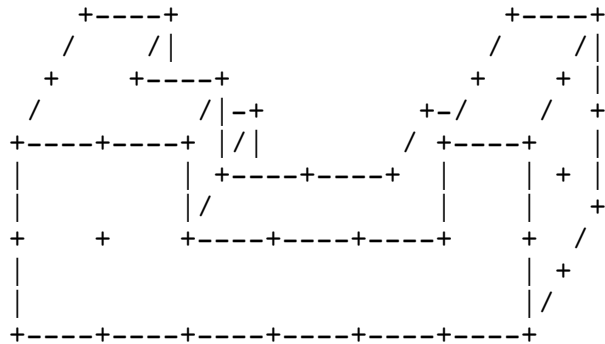

Piece 4

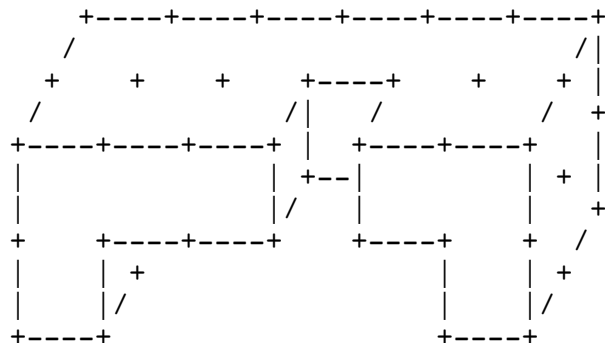
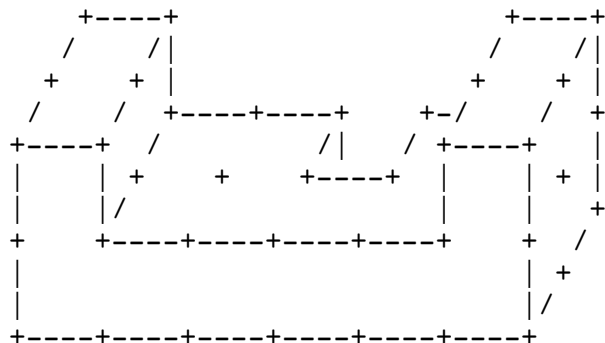

Piece 5

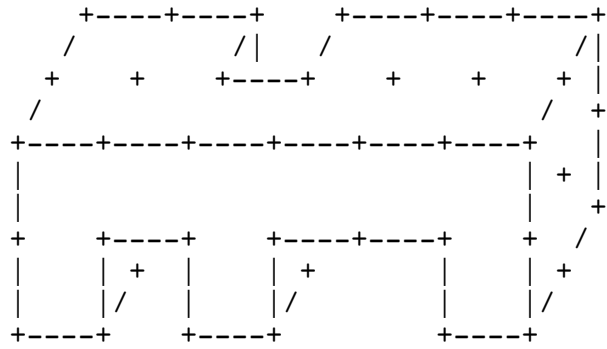
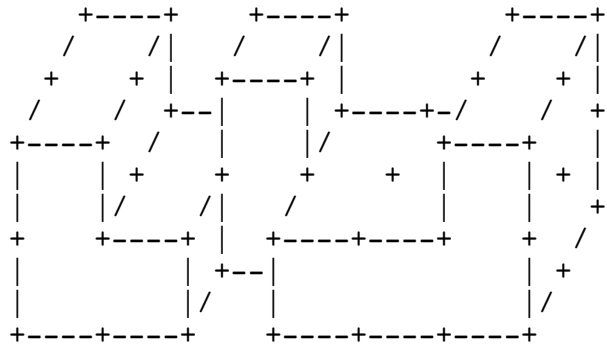

Piece 6

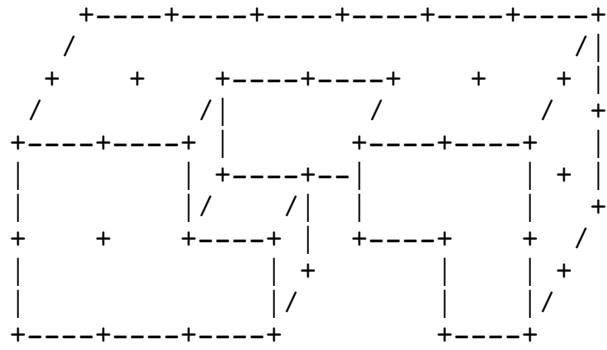
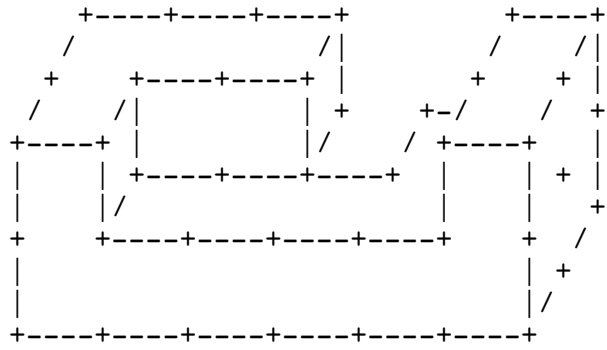

(last update 19-04-2002)

Burr BC UL6000 6-4

LL-format 00045115013504521130013324226664

Length 6

Piece 1

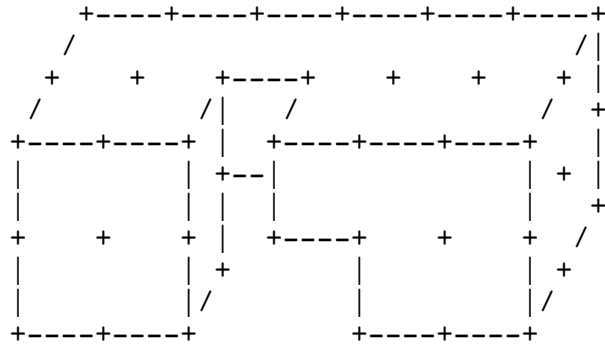
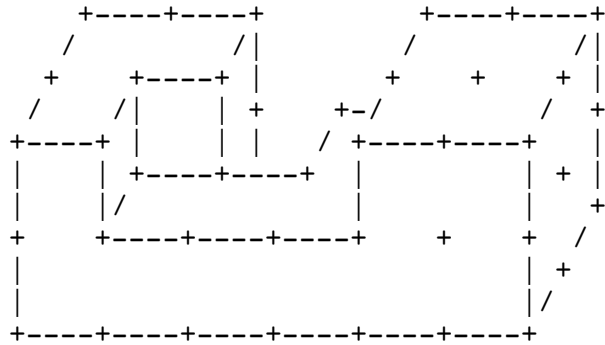

Piece 2

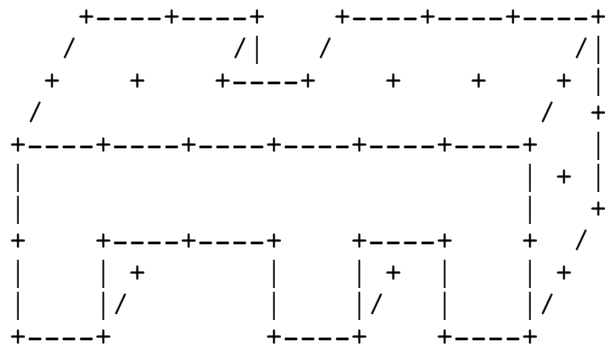
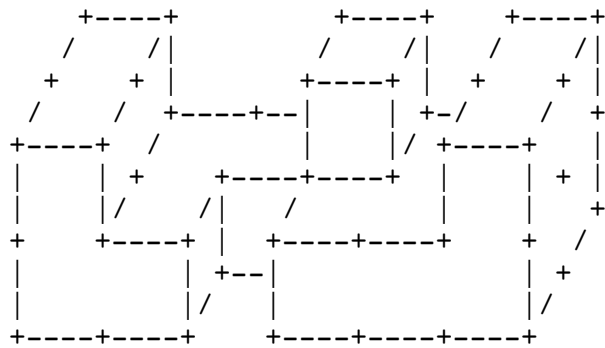

Piece 3

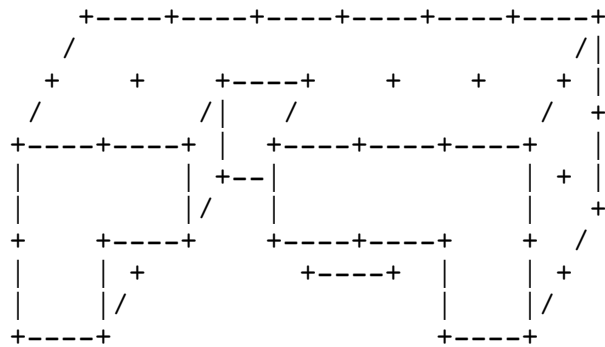
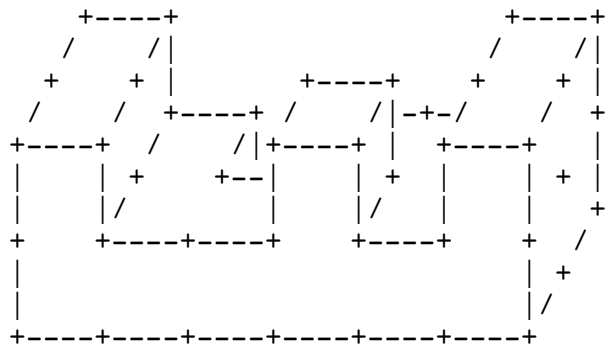

Piece 4

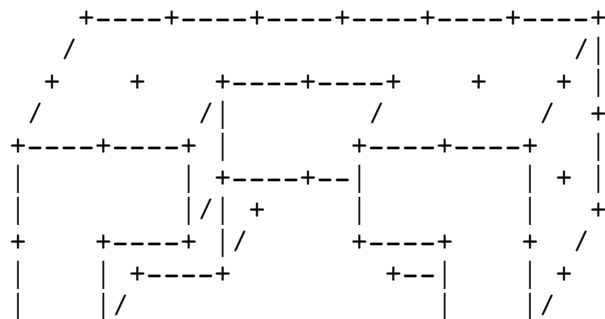
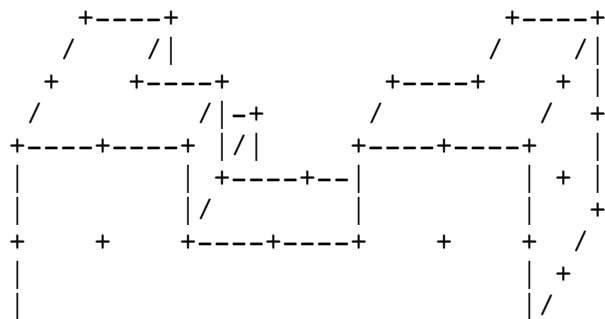

+-----+-----+-----+-----+-----+-----+

+-----+

+-----+

Piece 5

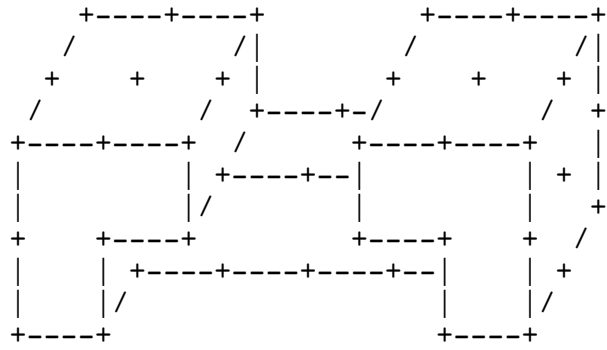
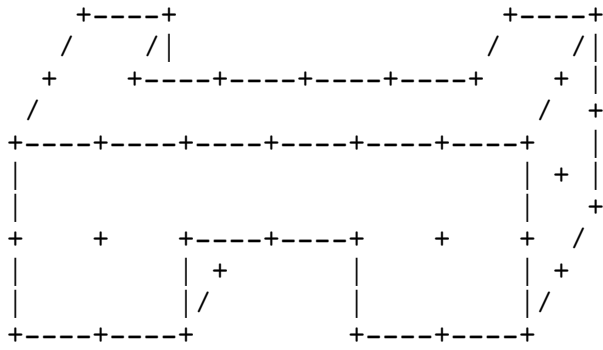

Piece 6

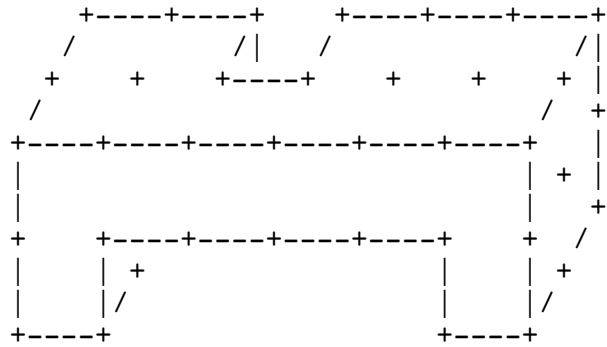
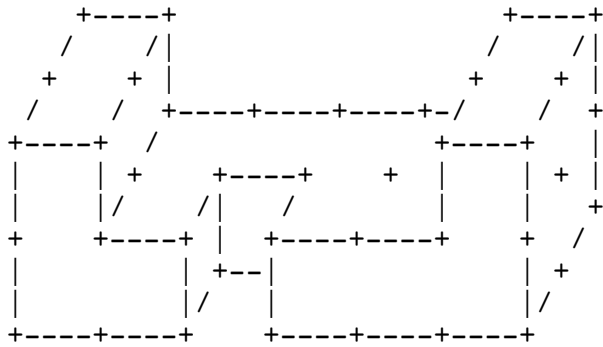

(last update 19-04-2002)

Burr BC UL5000 5-6

LL-format 55551131540550226033642204063636

Length 6

Piece 1

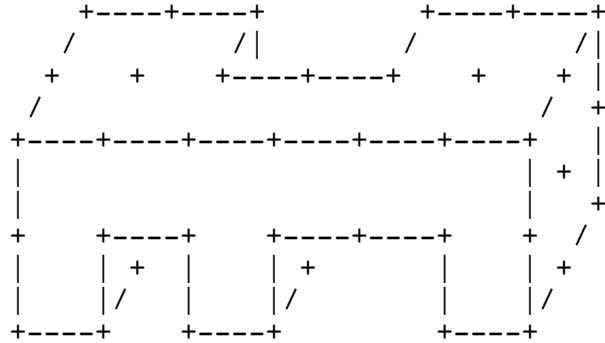
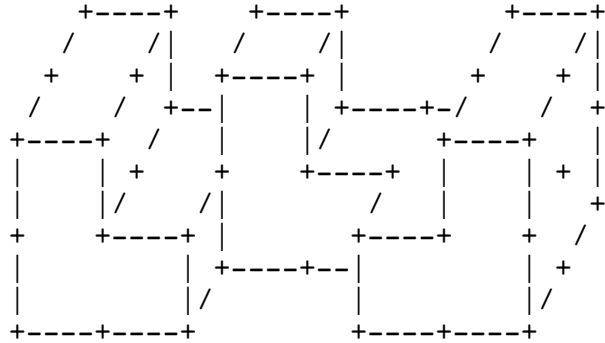

Piece 2

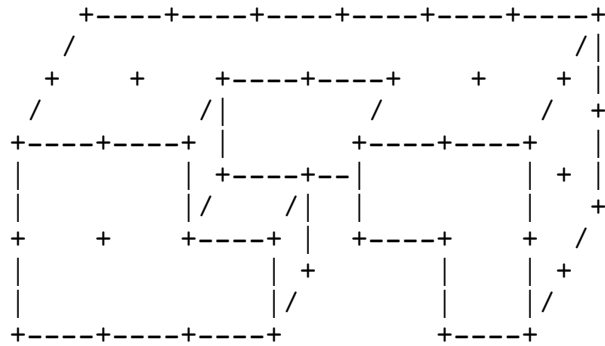
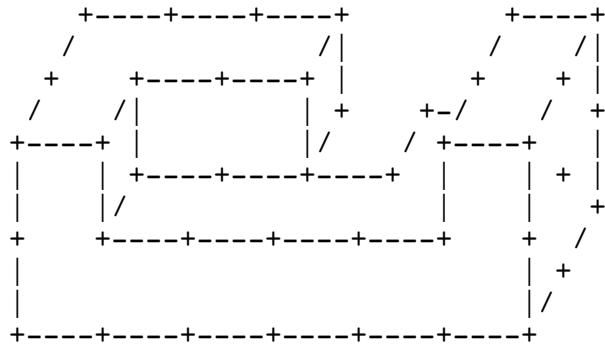

Piece 3

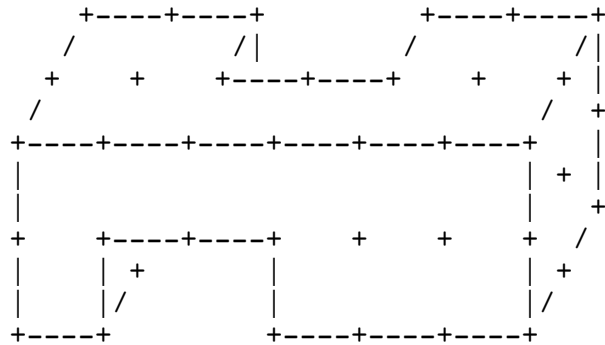
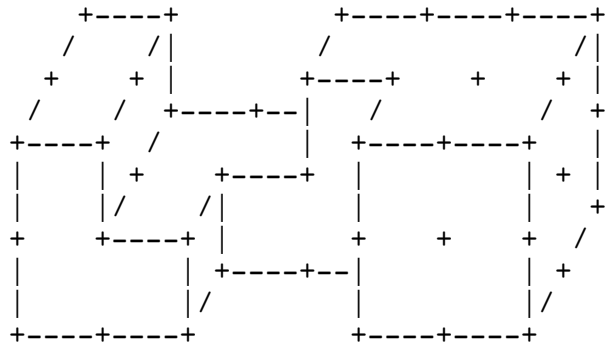

Piece 4

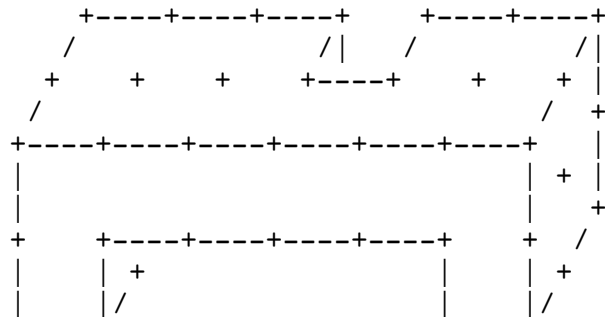
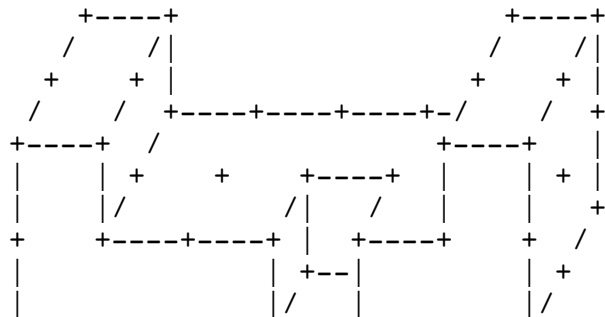

+---+---+---+ +---+---+

+---+---+

+---+

+---+

Piece 5

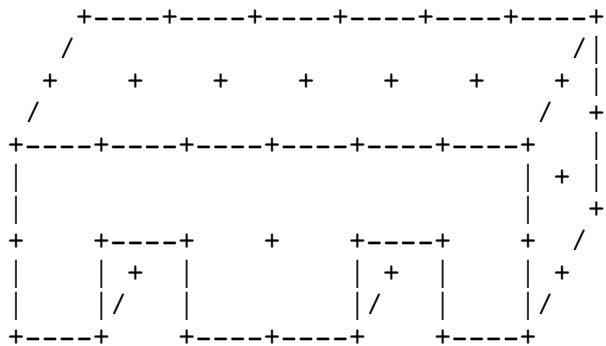
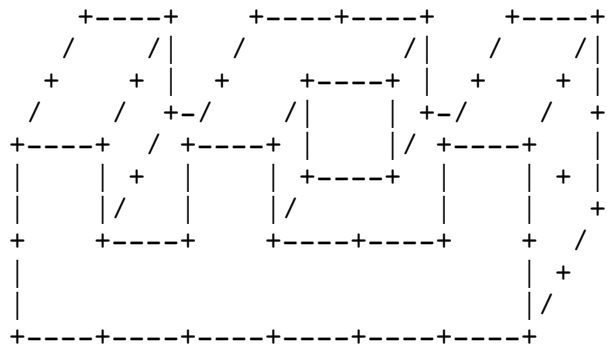

Piece 6

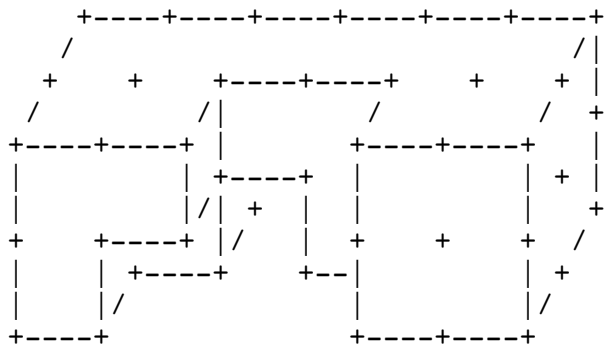
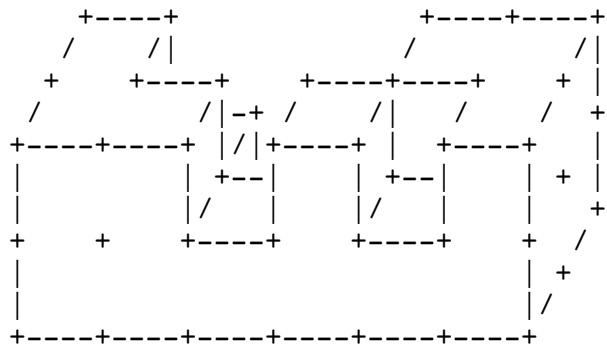

(last update 19-04-2002)

Burr BC L6000 2 sol 6-4/5-4

LL-format 35551131442250221131442002226060

Length 6

Piece 1

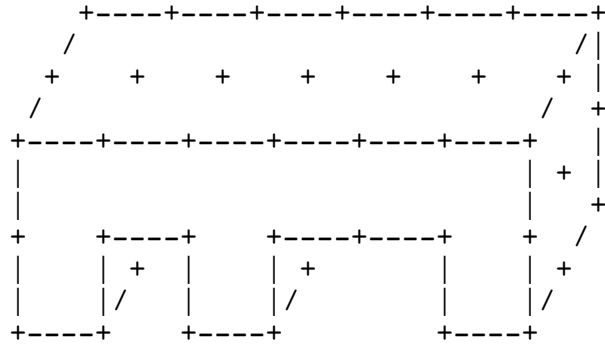
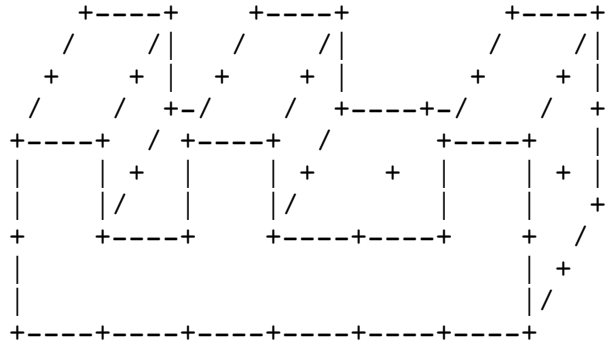

Piece 2

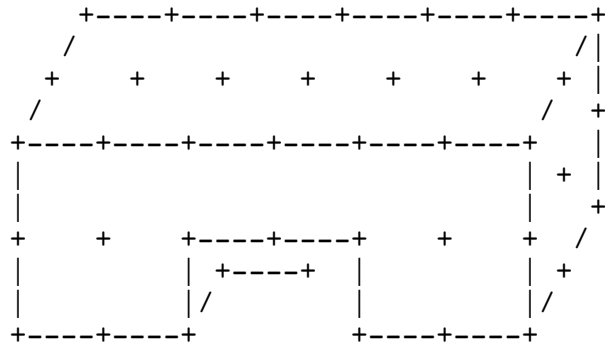
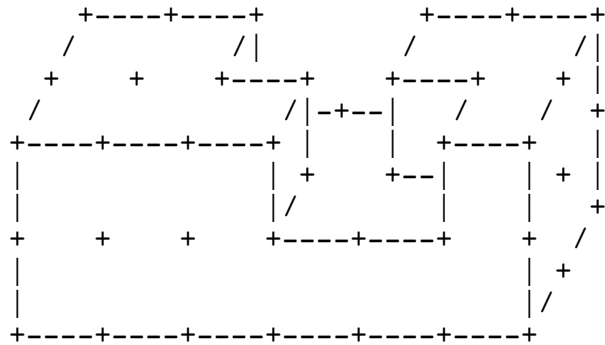

Piece 3

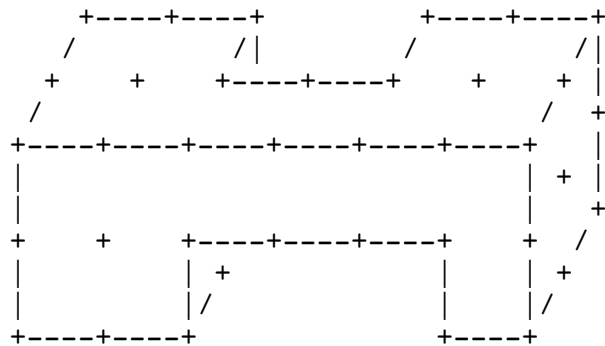
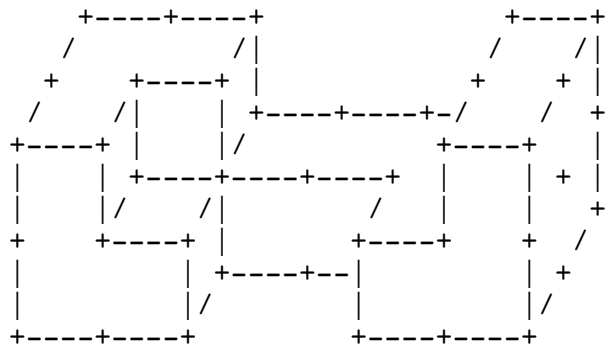

Piece 4

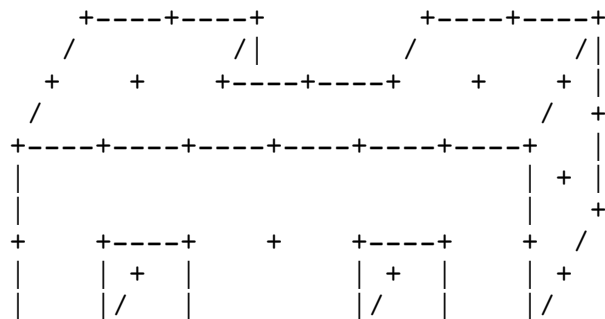
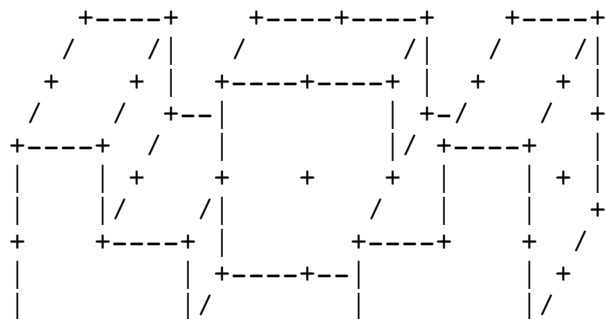

+---+---+

+---+---+

+---+

+---+---+

+---+

Piece 5

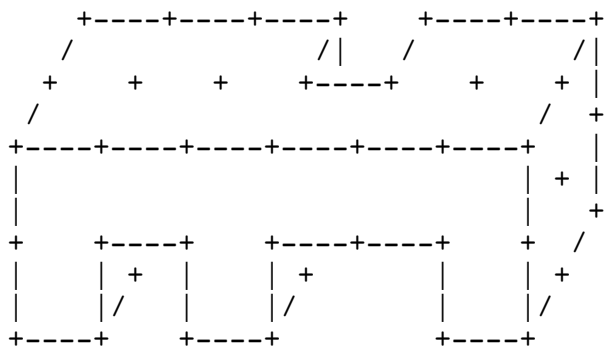
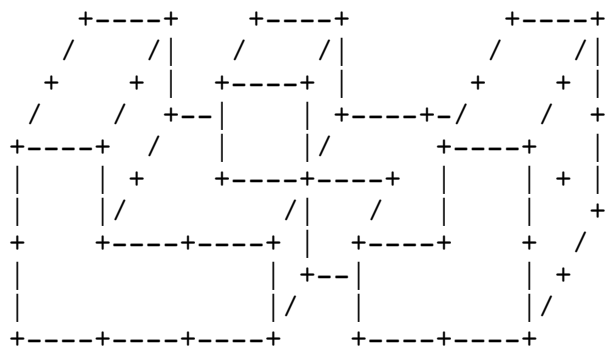

Piece 6

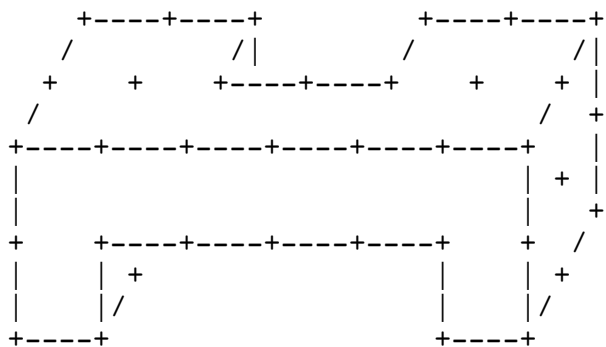
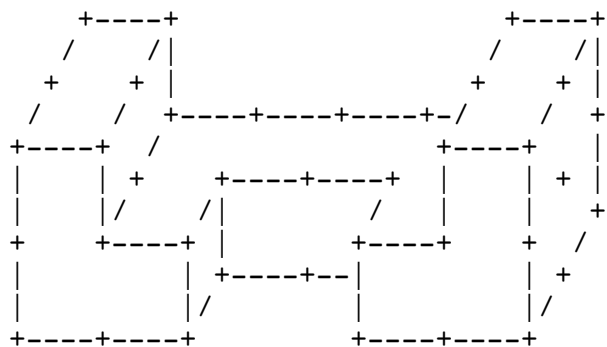

(last update 19-04-2002)

Burr Love's Dozen LC000

LL-format 55550130540004551133440602226060
Length 6

Note: The pieces are marked with letters O and K as indicated, although NOT at the front as shown, but on the OUTSIDE nearest 2x2 unit squares. The letters O and K should read OK.
The letter K is always written to the 'back' of the piece.
(The back in the left drawing is the 'bottom')
The letter O is always written to the 'inside' of the piece.
Please fit burr together first if in doubt.

Piece 1

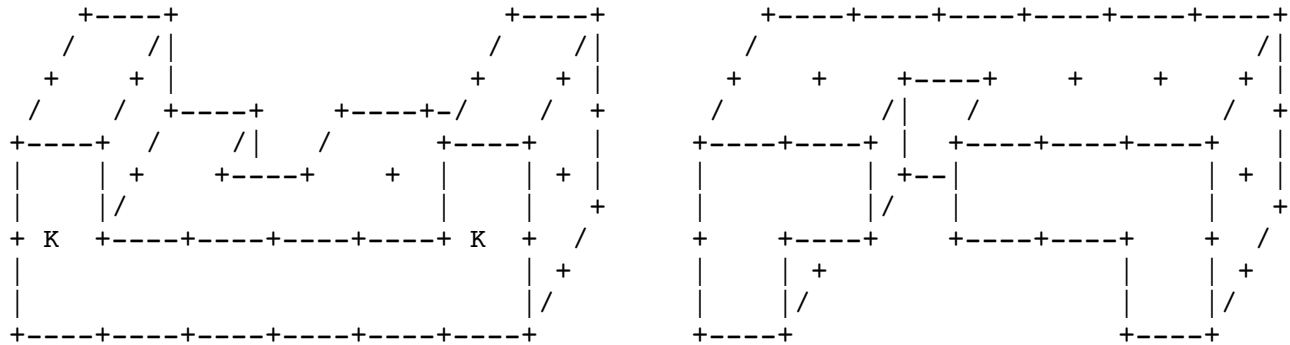

Blok 2

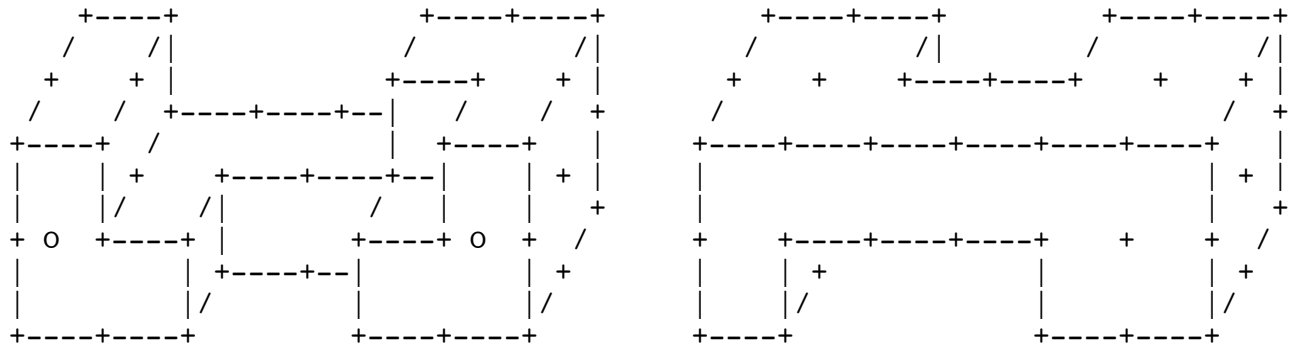

Blok 3

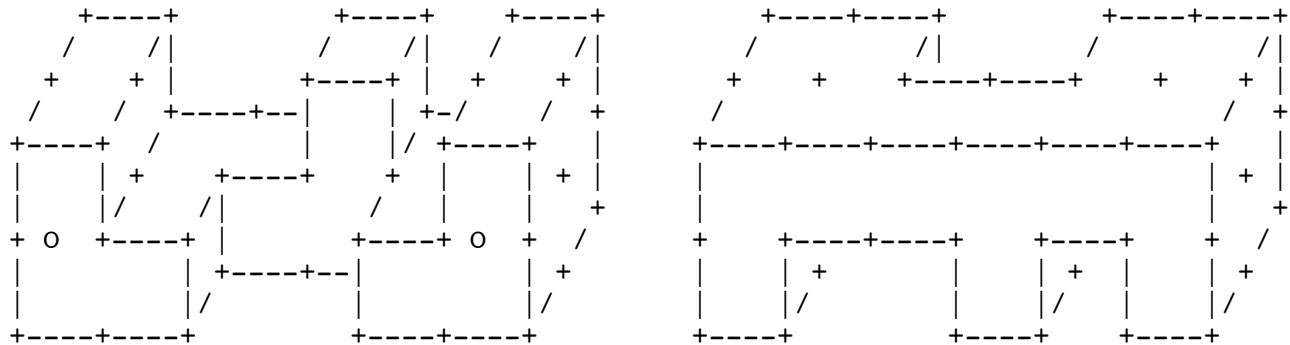

Blok 4



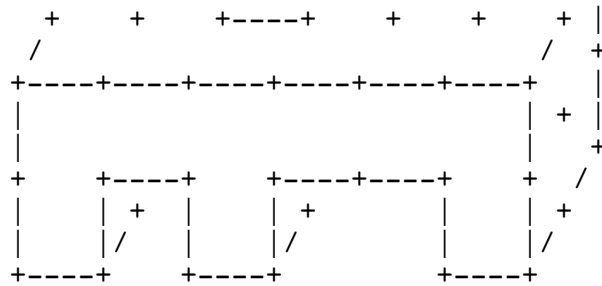
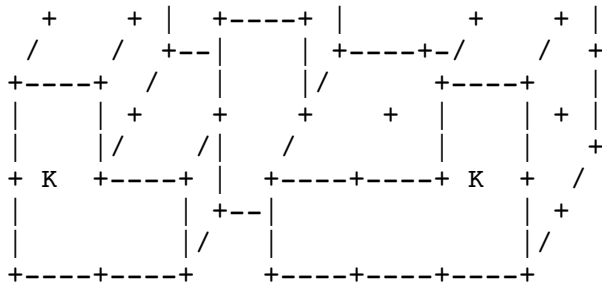

Blok 5

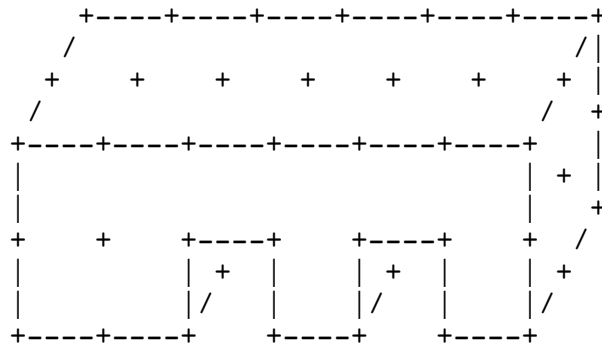
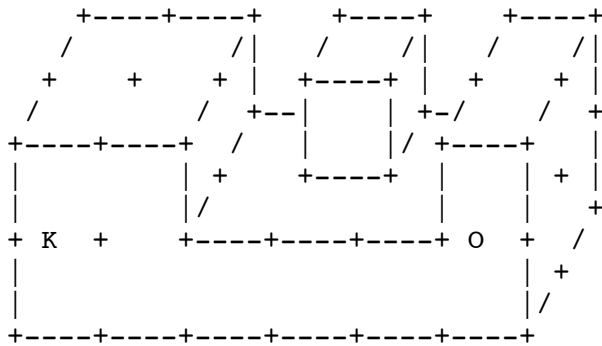

Blok 6

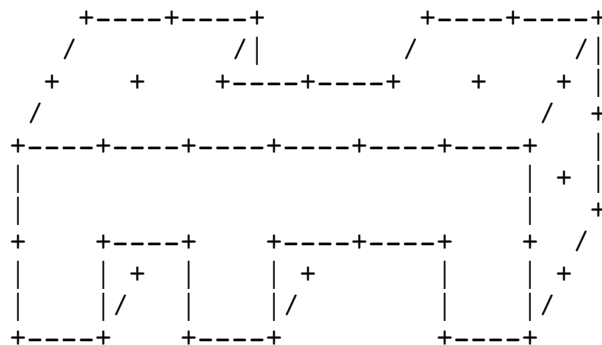
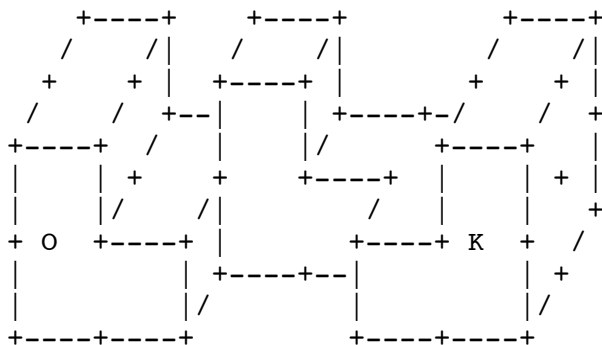

When the burr is put together, it will look like this. With gratitude to Interlocking Puzzles, who provided me with these pictures. Although the pictures are included to clarify the way the markings should be oriented, they also give a clue to the solution. However, you do not have to look at them any further...

The corner where three K's meet

The opposite corner

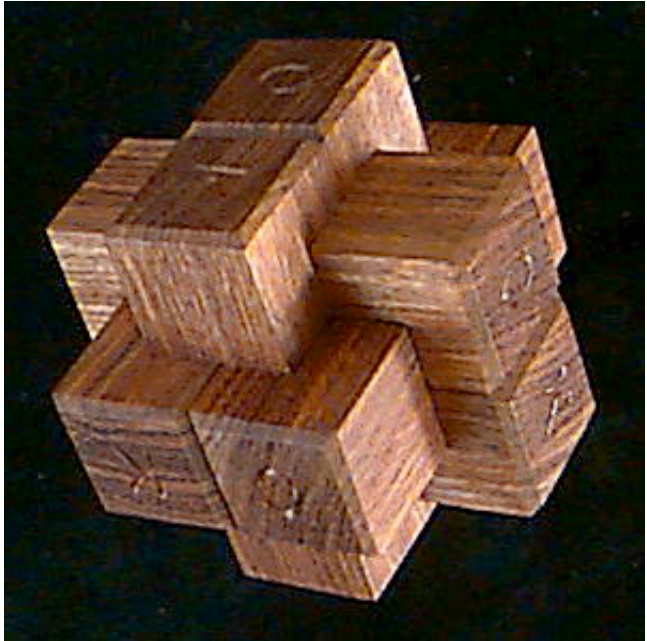
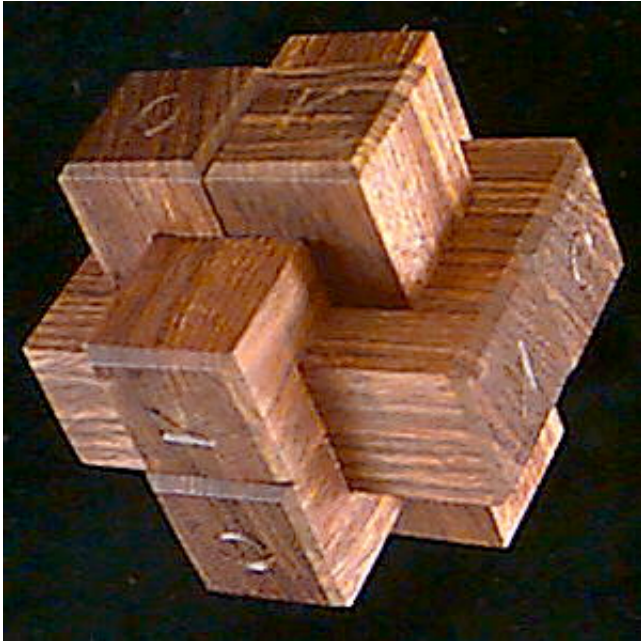

(last update 19-04-2002)